

# BLAST N' VAC<sup>®</sup> SYSTEM

## BNVS-325

# OPERATING INSTRUCTIONS

INVENTIVE MACHINE CORPORATION, P.O. BOX 7585, AKRON, OH 44306  
(330) 785-2500 (800) 325-1074 FAX (330) 785-2510

## TABLE OF CONTENTS

|        |   |    |
|--------|---|----|
| 1.0    | SET-UP PROCEDURE.....   | 1  |
| 2.0    | OPERATING PROCEDURE.....  | 2  |
| 2.1    | START-UP.....   | 2  |
| 2.2    | ROUTINE INTERMITTENT SHUTDOWN.....  | 3  |
| 2.3    | SHUT DOWN FOR RELOADING ABRASIVE.....   | 3  |
| 2.4    | FINAL SHUTDOWN.....   | 4  |
| 2.5    | MISCELLANEOUS.....  | 4  |
| 3.0    | MAINTENANCE.....  | 6  |
| 3.1    | DAILY MAINTENANCE.....  | 6  |
| 3.2    | WEEKLY MAINTENANCE.....   | 6  |
| 3.3    | MONTHLY MAINTENANCE OR 200 HOURS OF OPERATION.....  | 6  |
| 3.4    | REPLACING THE DIAPHRAGM.....  | 7  |
| 3.5    | CHECKING OR REPLACING METERING TUBE.....  | 7  |
| 4.0    | TROUBLESHOOTING.....  | 7  |
| 4.1    | PROBLEM-POOR PRODUCTION.....  | 7  |
| 4.2    | PROBLEM-PULSATING OR SURGING GRIT FROM NOZZLE.....  | 8  |
| 4.3    | PROBLEM-NO FLOW OF COMPRESSED AIR OR GRIT.....  | 8  |
| 4.4    | PROBLEM-FLOW OF AIR THROUGH THE NOZZLE, BUT LITTLE<br>OR NO FLOW OF GRIT.....   | 9  |
| 4.5    | PROBLEM-UNABLE TO STOP THE FLOW OF COMPRESSED AIR...  | 11 |
| 4.6    | PROBLEM-GRIT SURGING FROM NOZZLE WHEN POT IS<br>PRESSURIZED AND CONTROL HANDLE NOT<br>DEPRESSED.....  | 11 |
| 4.7    | PROBLEM-PREMATURE WEAR OF TEE UNDER SURE-FLO GRIT<br>VALVE.....   | 11 |
| 4.8    | PROBLEM-WHEN OPERATOR'S HANDLE IS FIRST DEPRESSED<br>GRIT AND AIR ARE NORMAL, BUT AFTER START<br>TIME, GRIT FLOW GRADUALLY STOPS, LEAVING<br>ONLY AIR FLOW..... | 11 |
| DIA 1  | BNVS-300 SYSTEM CONFIGURATION DIAGRAM.....  | 12 |
| DIA 2  | BNVS-305 SYSTEM CONFIGURATION DIAGRAM.....  | 13 |
| FIG 1  | SUPERBLAST WITH MANUAL CONTROLS.....  | 14 |
| FIG 2  | SUPERBLAST WITH SAF-STOP II, 780 SERIES PNEUMATIC<br>REMOTE CONTROLS INSTALLED.....   | 14 |
| FIG 3  | SYSTEM VALVE REFERENCE GUIDE.....   | 15 |
| FIG 4  | AUTOMATIC HIGH PERFORMANCE SURE-FLO (INTERNAL PARTS)  | 16 |
| FIG 5  | AUTOMATIC SURE-FLO (SPRING AND DIAPHRAGM ASSEMBLY)..  | 16 |
| FIG 6  | AIR FLOW IN BLAST POT ILLUSTRATION.....   | 17 |
| FIG 7  | BNV-3 WORKHEAD COMPONENTS.....  | 18 |
| FIG 8  | BNV-3 BRUSH SET USE GUIDE.....  | 19 |
| FIG 9  | BNV-4/BNV-6 WORKHEAD COMPONENTS.....  | 20 |
| FIG 10 | BNV-4/BNV-6 WORKHEAD PARTS BREAKDOWN.....   | 21 |
| FIG 11 | PRESSURE REGULATOR BREAKDOWN.....   | 22 |

In addition to the Blast N' Vac System, you will need two items to begin operation -- the blasting abrasive of your choice and a compressed air supply with a minimum 1-1/4" ID air supply line. To operate the system at conventional 100 psi blast pressures you will need to provide a minimum of 300 cfm of compressed air.

#### 1.0 SET-UP PROCEDURE (reference figures 1, 2, 3)

- a. Unpack and lay out for identification all loose parts. System containers are often used as packaging, so be sure to check inside each for loose parts.
- b. Pneumatic remote controls with dual lines (fig 2 item 24) are supplied with system. Fittings on one end are already connected to remote control switch. Connect the other ends to the proper fittings on the system's control panel.
- c. Connect the blast line to the fitting (fig 1 item 8) on the bottom of the blast machine. Be sure to secure with a safety wire.
- d. Connect the short 3" vacuum hose from the recovery container to the back of the control panel, then the 50' x 3" vacuum hose from the front side of the control panel to the workhead.
- e. Install an air coupling (not supplied) to the compressed air inlet point for the system (1 1/4" pipe nipple). Do not use a coupling that restricts air flow.
- f. Connect the air line from the compressor to the air coupling just installed on the system. Keep length as short as possible. For optimum blasting productivity, use an air line at least three times the I.D. of the nozzle orifice. 1 1/4" I.D. or larger hose is generally used.
- g. Hook-up the 2" vacuum lines to container lids as in system configuration diagram. These are color coded for your convenience.
- h. Close Vacutrans air supply valve (fig 3 item 29).
- i. Close Blast Pot air supply valve (fig 3 item 17).
- j. Close exhaust valve (fig 3 item 18).
- k. Open choke valve (fig 3 item 4).
- l. Close Sure-Flo grit valve on bottom of blaster (fig 3 item 28) by rotating "T" handle clockwise. Open pressure regulator (fig 3 item 30) by turning fully clockwise.

- m. Fill water bath container to 1/3 level (bottom of standpipe should be submerged in the water).
- n. Re-set lid on water bath and be sure lids on both it and material recovery container are sitting securely on gasket material and that moisture barrier inside drum is positioned properly on its hanging brackets.
- o. Lay out vacuum and blast hoses WITH ATTENTION TO MINIMIZING BENDS.
- p. Thread blast nozzle into holder on end of blast hose.
- q. Thread workhead onto same holder on end of the blast hose. Thread until snug then back off one full turn.
- r. Clamp 3" vacuum hose onto vacuum port of workhead.
- s. Be sure workhead center tube (attached over end of blast nozzle in BNV-3 tool and set into tool body on BNV-4) and brushes (one in BNV-4 and two in BNV-3) are installed. NEVER USE BNV-3 TOOL WITHOUT DOUBLE BRUSH ARRANGEMENT.
- t. Fill the blaster with dry grit through the large 6" opening in the top. Do not overfill. BNV system grit capacity is 6.5 cu. ft.
- u. Make sure the operator is equipped with the recommended protective equipment. NIOSH requires the use of an air-fed hood, remote controls, canvas jacket, pants and leather gloves. It is recommended that the air-fed hood be equipped with an air purifier, free air pump and/or CO (carbon monoxide) monitor.

YOU ARE NOW READY TO BEGIN OPERATION

2.0 OPERATING PROCEDURES (reference figure 3)

2.1 START-UP

- a. Turn on compressor.
- b. Open Vacutrans air supply valve (fig 3 item 29). Always open this valve before the blast pot air supply valve (fig 3 item 17).
- c. Open blast pot air supply valve (fig 3 item 17). Be sure exhaust valve (fig 3 item 18) is closed. Blast pot will pressurize.

- d. Depending on the combination of the coating being removed (if any), the composition of the substrate and the type of abrasive, the pressure of the blast stream may need to be adjusted to suit the needs of the particular job. Removing an epoxy coating from steel and achieving a white metal blast spec with sand would require at least 100 psi whereas using plastic blast media to remove the same coating from a thin aluminum surface may only use 40 psi. Pressure regulator (fig 3 item 30) should be set full open (clockwise rotation of "T" handle) as described in set up procedure (section 1.0). This will allow blasting at the full pressure the compressor can supply. To blast at lower pressures turn "T" handle counter-clockwise while bleeding air out the exhaust valve (fig 3 item 18) or the petcock on the bottom of the moisture trap. The regulator on the Blast N' Vac System is a non-relieving type. Clockwise turning of the adjusting screw will increase pressure. Reverse rotation of the adjusting screw will not reduce pressure unless the pressure is "bled off".
  - e. Grab Blast N' Vac workhead and put in contact with surface to be blasted. Close remote control switch and blasting will begin. Initially no abrasive will come from blast nozzle since the grit valve (fig 3 item 28) was closed in the set-up procedure (section 1.0). Have a second person adjust this valve out (counter-clockwise rotation of "T" handle) until abrasive flow is visibly doing the proper amount of work. From the point of first noticing abrasive flow it will take only 5-6 full turns of T-handle to fully open valve. Past that point the handle will still turn but will have no effect on abrasive flow.
  - f. Remote control switch must be constantly depressed to continue blasting.
  - g. Brushes on end of workhead must be kept in constant contact with surface to achieve full vacuum recovery and control of abrasive and dust.
- 2.2 ROUTINE INTERMITTENT SHUTDOWN - Simply release remote control switch and blasting will stop. Vacuum runs constantly, remote switch controls blasting only. Depending on hose lengths there is a slight delay in actual start-up and shut-down of abrasive flow when actuating the switch. Keep head in contact with surface while delay is taking place.
- 2.3 SHUT DOWN FOR RE-LOADING ABRASIVE
- a. Release remote control switch.
  - b. Close blast pot air supply valve (fig 3 item 17).

- c. Close Vacutrans air supply valve (fig 3 item 29).
  - d. Open blast pot exhaust valve (fig 3 item 18).
  - e. Fill blast machine manually if using "300" system or through hopper dump valve if using "305" system. Empty or replace recovery drum in "300" type system.
  - f. Open Vacutrans air supply valve (fig 3 item 29), close exhaust valve (fig 3 item 18) and open blast pot air supply valve (fig 3 item 17). You are now ready to begin blasting again.
  - g. During this shut-down is a good time to check brushes and center tube in workhead for wear and replacement. Replace brushes when excessive abrasive loss or wear is noted. Check center tube for wear each time brushes are replaced and change it when end begins to flare. Also periodically check water level in water bath dust filter as water loss will occur over time.
- 2.4 FINAL SHUT-DOWN - If possible, schedule final shut-down to coincide with the blast pot being empty of abrasive.
- a. Proceed as in 2.3 a, b, c & d (SHUT DOWN FOR RE-LOADING ABRASIVES).
  - b. Close air supply valve on compressor and shut down according to manufacturers instructions.
  - c. Bleed off air in supply line from compressor to system by opening blast pot air supply valve (fig 3 item 17) until pressure is released, then close again.
  - d. System is now completely de-pressurized.
- 2.5 MISCELLANEOUS
- a. The center tubes in all Blast N' Vac models are high wear items. On the BNV-3 tool the center tube slides over the end of the blast nozzle. In the BNV-4 the center tube slides into the body of the workhead and is secured with set screws. These center tubes should be checked on an hourly basis and replaced when they show excessive wear. **PROLONGED BLASTING WITH A DETERIORATED CENTER TUBE WILL DESTROY CRITICAL PARTS OF THE WORKHEAD.**
  - b. The BNV-4 workhead utilizes a single brush. The BNV-3 uses a two brush set-up. As the interior brush on the BNV-3 nears destruction be sure to replace it before destroying the outer

brush. Brushes should generally be replaced when abrasive loss at the blast point is noticed. NEVER USE BNV-3 WITH ONLY ONE BRUSH. AN INNER AND OUTER BRUSH SHOULD ALWAYS BE USED IN TANDEM.

- c. For optimum operation and abrasive recovery, try to keep the unit as perpendicular to the work surface as possible. With a little practice, your technique and efficiency will improve by the hour. ON BNV-3 AVOID PUTTING TOO MUCH FORWARD PRESSURE ON BRUSHES CAUSING THEM TO BEND INTO BLAST AREA AS YOU MOVE.
- d. When moving the system from place to place be sure all components are secure. ON RECYCLE MODELS BE SURE RECOVERY HOPPER IS NOT ON TOP OF BLAST POT WHEN MOVING.
- e. Abrasive blasting can produce harmful levels of respirable dust. Accident or improper handling of this equipment can create such dust. Breathing protection is recommended. Eye and ear protection is recommended during operation.

\* \* \* CAUTIONS \* \* \*

When changing workheads on BNV systems be certain to remember to change to the proper center tube. The BNV-3 workhead (no wheels) uses only the specially sized no. 4 nozzle and the center tube slides directly onto the end of the nozzle. The BNV-4 workhead (with wheels) uses the same nozzle but the center tube MUST be removed as the center tube for the BNV-4 workhead slides into the body of the tool and is held in place, with set screws.

Never turn off air compressor before de-pressurizing the blast machine.

Condensation can occur overnight. Therefore, empty the blaster of grit at the end of each day. The most efficient method to empty the blaster is through normal blasting. However, if you want to empty the blaster quickly, the following should be done:

First, remove the blast nozzle. Close the choke valve (fig 3 item 4) and open the Sure-Flo grit valve (fig 3 item 28). Close the exhaust valve (fig 3 item 18) and open the blast pot air supply valve (fig 3 item 17). Close remote control switch. Grit will be forced out of the machine in a dense phase through the blast hose. The pressure regulator can be used to control the velocity of the abrasive stream. When all abrasive is cleared from blast machine follow normal shut-down procedure.

Cover blast pot if stored outside to prevent rain from entering pressure vessel.

### 3.0 MAINTENANCE (reference figures 1-5)

#### 3.1 DAILY MAINTENANCE (reference figures 1 and 2)

- a. All rubber washers on nozzle, blasting hose and air line couplings must be properly installed and in good condition.
- b. Check operator's protective equipment, such as blasting hoods, gloves and protective clothing.
- c. All couplings must be equipped with safety wires.
- d. The nozzle (fig 1 item 16) must be tightly secured to nozzle coupling (fig 1 item 15). Do not use the nozzle without a washer. This will cause premature wear to nozzle and coupling.
- e. Open the drain valve on the moisture & oil separator (fig 1 item 11) to remove any accumulation of moisture.
- f. Dual line hose (fig 2 item 24) must be in good operating condition and tightly secured at the operator's control handle and at the blaster.

#### 3.2 WEEKLY MAINTENANCE (reference figure 1)

- a. Check the nozzle for wear. A nozzle is considered worn when it wears to half again its original size. A drill bit can be used to measure the nozzle opening. Blasting with a worn nozzle may reduce operating pressure which will reduce blasting speed.
- b. The specially constructed blasting hose should be checked for signs of wear. Replace if any soft spots are found.
- c. Inspect the sealing "O" ring (fig 1 item 1) and sealing plunger (fig 1 item 2) for signs of wear. Replace if worn.
- d. Check all valves for good operating condition.

#### 3.3 MONTHLY MAINTENANCE OR 200 HOURS OF OPERATION (reference figures 3 and 4)

- a. Check metering tube (fig 4 item 2B) in the Sure-Flo grit valve (fig 3 item 28) for wear or ruptures. In the automatic Sure-Flo grit valve, the tube may be worn if the nozzle does not shut off when the remote control handle is released. Replace if defective.
- b. Check rubber diaphragm (fig 4 item 14B) in the automatic Sure-Flo grit valve to see that it is in good operating condition. Air leaking through or around a diaphragm will escape through the vent hole in the diaphragm cover indicating need for replacement.



### 3.4 REPLACING THE DIAPHRAGM (reference figures 4 and 5)

Loosen jam nut (fig 4 item 11B) and back spring tensioner (fig 4 item 12B) with handle (fig 4 item 9B) approximately 1 1/2" from Sure-Flo spring enclosure (fig 4 item 13B). It is not necessary to totally remove tensioner. Remove the six bolts holding the spring enclosure (fig 4 item 13B) to diaphragm cover (fig 4 item 15B). Unscrew plunger (fig 5 item 3C), remove steel washer (fig 5 item 4C) and the spring and diaphragm assembly (fig 5 item 7C). After replacing old diaphragm with a new one, re-install steel washer (fig 5 item 4C), rubber washer (fig 5 item 5C) and plunger (fig 5 item 3C). Be sure washers are centered on spring retaining nut prior to tightening. Reassemble spring enclosure in reverse order.

**IMPORTANT: NEVER DISASSEMBLE SPRING ASSEMBLY.** The spring assembly is under compression. Removing components could cause injury. Replacement requires purchase of a complete assembly (P/N 290296).

### 3.5 CHECKING OR REPLACING METERING TUBE (reference figure 4)

Shut off main air valve and de-pressurize blaster. Disconnect blast hose from tank coupling. Disconnect flexible choke line hose assembly from Sure-Flo. Disconnect 1/4" air control hose from adaptor (fig 4 item 18B) on Sure-Flo diaphragm cover (fig 4 item 15B). Back jam nut (fig 4 item 11B) spring tensioner (fig 4 item 12B) and handle assembly (fig 4 item 9B) out from spring enclosure (fig 4 item 13B) approximately 1 1/2". It is not necessary to remove completely from the Sure-Flo. Remove four carriage bolts holding lower flange (fig 4 item 17B) to body (fig 4 item 4B). Remove lower flange back bolt (fig 4 item 3B) to relieve pressure on the metering tube (fig 4 item 2B). Remove old tube and install new metering tube. Reassemble bottom of Sure-Flo to top flange using four carriage bolts. Thread jam nut, spring tensioner and handle assembly back into Sure-Flo spring enclosure. Completely tighten bolt (fig 4 item 3B).

**WARNING: SURE-FLO GRIT VALVE SHOULD NOT BE DISASSEMBLED WHILE THE BLASTER IS UNDER PRESSURE.**

## 4.0 TROUBLESHOOTING (reference figures 1-5)

### 4.1 PROBLEM - POOR PRODUCTION

- a. Air pressure is an extremely important factor. In most cases poor production can be traced to lack of air. This is generally caused by the following:

- 1) The compressor is too small for the nozzle being used.

- 2) The I.D. size of the air line is too small. Generally 1 1/4" I.D. or larger air hose should always be used.
  - 3) Restriction of air caused by improper fittings.  
As a general rule the blasting pressure at the nozzle should be approximately 100 P.S.I.
- b. Grit size too small. A general rule to remember: "The thicker the material being removed, the coarser or larger the grit particle size should be".
  - c. Blast finishing a part which is oily or wet - the surface must be absolutely dry and free of any oil, grease, water, etc.
  - d. Operating with an improper setting at the grit valve - if the mixture is either too rich or too lean it will affect the operator's performance.

#### 4.2 PROBLEM - PULSATING OR SURGING OF GRIT FROM THE NOZZLE

(reference figure 3) Note: When blasting first starts, there will be an initial surge of grit from the nozzle. This is caused by grit accumulated in the blast hose. After a few seconds, normal blasting should resume. If not, check the following:

- a. Operating with the choke valve (fig 3 item 4) partially closed. This valve must remain open during blasting operations. The choke valve is designed to help in removing most obstructions found in the pressure vessel and grit valve. By closing the choke valve, all the compressed air is forced into the pressure vessel helping to push the obstruction down into the tee at the bottom of the Sure-Flo. Opening the choke valve permits air to flow through the line, pick up the debris or obstruction and carry it out the blast hose to the nozzle.
- b. Operating with an improper setting at the grit valve. If the grit mixture is too rich it will pulsate. Gradually reduce the flow of grit. Note: The Sure-Flo grit valve only requires 1/4 turn to affect the flow of grit and will take approximately 5 full turns to go from fully closed to fully open.
- c. Operating with damp grit. Grit must be absolutely dry to flow evenly through the Sure-Flo and blast hose. On humid days, or when using an older compressor, it may be required to operate with the moisture separator drain cocked slightly opened. If conditions persist, an air-drying system may need to be employed in line between the compressed air source and the blast machine.

#### 4.3 PROBLEM - NO FLOW OF COMPRESSED AIR OR GRIT (reference figures 1-3)

- a. Clogged nozzle - De-pressurize blaster and remove the nozzle from the coupling and inspect for any foreign material that may be lodged in the orifice opening. **IMPORTANT: DO NOT REMOVE NOZZLE WHEN BLASTER IS UNDER PRESSURE.**
- b. Clogged blasting hose. Remove the nozzle and washer from the coupling and while someone is FIRMLY holding the blasting hose, do the following:
  - 1) Close the Sure-Flo grit valve (fig 3 item 28).
  - 2) Close the exhaust valve (fig 3 item 18).
  - 3) Open the main valve (fig 3 item 17).
  - 4) Depress the remote control handle.This will force the compressed air through your blasting hose and dislodge packed grit. You may have to disconnect the blasting hose and inspect the tank coupling for any foreign material.
- c. Remote Control Air Check - (reference figures 1 and 2)
  - 1) Make sure 1/4" petcock (fig 1 item 12) is open.
  - 2) Remove the plug in the 1/4" pipe cross under the automatic air valve (fig 2 item 20). When operator's handle is depressed, air should escape (a gauge screwed into this opening should show minimum 60 PSI with 90 PSI supply). If no air escapes (or if pressure is less than 60 PSI) check dual lines and fittings for kinks or leaks. Trace control air through system as follows: Remove black line at handle (fig 2 item 23) - air should escape. Re-connect black line and remove yellow line at handle - air should escape when handle is depressed. By tracing air flow in this manner back through the blaster, location of obstruction or leak can be determined.
  - 3) If control air of adequate pressure is reaching automatic air valve (fig 1 item 20), problem is ruptured diaphragm in this valve. Note: A small volume of air bleeding from the stem of the automatic air valve will be noticed when air control line is pressurized. This bleed is a safety feature which shuts down the system if hoses should be accidentally crimped.

- 4.4 PROBLEM - FLOW OF AIR THROUGH THE NOZZLE, BUT LITTLE OR NO FLOW OF GRIT (reference figures 1, 3, 4, 5)
- a. Operating with an improper setting at the grit valve (fig 3 item 28). If the mixture is too lean, little or no grit will be supplied to the nozzle.

- b. Clogged nozzle. Sometimes a clogged nozzle will allow air to pass, but little or no grit. Remove the nozzle (fig 1 item 16) from the coupling (fig 1 item 15) and inspect.

IMPORTANT: DO NOT REMOVE NOZZLE WHEN BLASTER IS UNDER PRESSURE.

- c. Blaster is empty. Refill with grit.
- d. Contaminated grit - Grit contaminated with moisture, excess fines, foreign material, large articles can interrupt grit flow. This free flow is necessary for effective blasting.
- e. Clogged grit valve
  - 1) Adjust the grit valve (fig 3 item 28) to full open position. While the machine is blasting, close the choke valve (fig 3 item 4) for a few seconds; then open it fully. Doing this three or four times should clear any temporary blockage. Reset the grit valve and continue blasting.
  - 2) If Step #1 is not successful, de-pressurize the blaster and back out the fixed bolt (11B) and spring tensioner (12B) with tee handle at least 2/3". This will relieve all pressure on the tube and allow it to open full. Choke the machine as in Step 1.
  - 3) If step 2 is not successful de-pressurize the blaster. Remove the lower flange housing (fig 4 item 17B) from the regulator body. Inspect bottom opening of tank with flashlight. Also, check metering tube in regulator. Remove foreign material causing blockage. Reassemble bottom half of regulator with metering tube to top flange. Continue blasting.
- f. Air leaks around Sure-Flo diaphragm assembly when pot is pressurized and blasting.
  - 1) Tighten the six bolts around outside of spring enclosure (fig 4 item 13B). If this fails to stop leaks proceed to next step.
  - 2) Disassemble spring enclosure, check diaphragm (fig 4 item 14B), tightness of plunger (fig 4 item 5B and fig 5 item 3C), and "O" rings (fig 4 item 6B). Replace any worn part and re-tighten plunger.
  - 3) Plunger frozen in the closed position. Disassemble diaphragm body. Inspect plunger and plunger guide (fig 4 item 5B and fig 4 item 16B), replace if scored or frozen. Note: A new "O" ring (fig 5 item 2C) should be used and a light film of white grease applied during re-assembly.

- 4.5 PROBLEM - UNABLE TO STOP THE FLOW OF COMPRESSED AIR (reference figure 1) When hand pressure is removed from the operator's control, the compressed air should stop immediately. If the compressed air does not stop, the problem is in the automatic air valve or operator's control.
- a. Check for a sticking plunger in the operator's control handle. This can be done as follows. Remove the yellow return line just behind the operator's control handle, when the handle is depressed, air should flow from the disconnected fitting; when the handle is released, the flow of air should immediately stop. If flow does not stop, disassemble control handle and clean.
  - b. Check that the plunger in the automatic air valve can (fig 1 item 20) move freely. After de-pressurizing the tank and shutting off the inlet air supply, remove the four bolts holding on the automatic air valve cover plate. It should be possible to move the center stem up and down. If stem does not move freely, disassemble and clean.
- 4.6 PROBLEM - GRIT SURGING FROM NOZZLE WHEN POT IS PRESSURIZED AND CONTROL HANDLE NOT DEPRESSED (reference figures 4 and 5)
- a. Operating with spring tensioner (fig 4 item 12B) and/or bolt (fig 4 item 3B) not fully seated against body. Turn in until fully seated as shown in Fig. 4.
  - b. Ruptured or worn metering tube (fig 4 item 2B). Disassemble metering tube body. Inspect metering tube and replace if defective.
  - c. Plunger (fig 4 item 5B) frozen in fully open or partially opened position. Disassemble diaphragm body.  
Note: A new "O" ring (fig 5 item 2C) should be used and a light film of white grease applied during re-assembly.
- 4.7 PROBLEM - PREMATURE WEAR OF TEE UNDER SURE-FLO GRIT VALVE
- a. Operating with choke line valve partially closed. The choke line should always be fully open during blasting.
  - b. Operating with worn metering tube in Sure-Flo allows air and grit to leak through tube even when not blasting. Replace tube.
- 4.8 PROBLEM - WHEN OPERATOR'S HANDLE IS FIRST DEPRESSED GRIT AND AIR ARE NORMAL BUT AFTER START TIME GRIT FLOW GRADUALLY STOPS LEAVING ONLY AIR FLOW. (reference figure 4)
- a. Leak through or around Sure-Flo diaphragm. If air escapes through vent hole in Sure-Flo housing (fig 4 item 15B) the Sure-Flo diaphragm is defective or its connecting hardware is not tightened properly.

# BNVS-300 SINGLE VACUTRANS BLAST N' VAC SYSTEM non-recycling

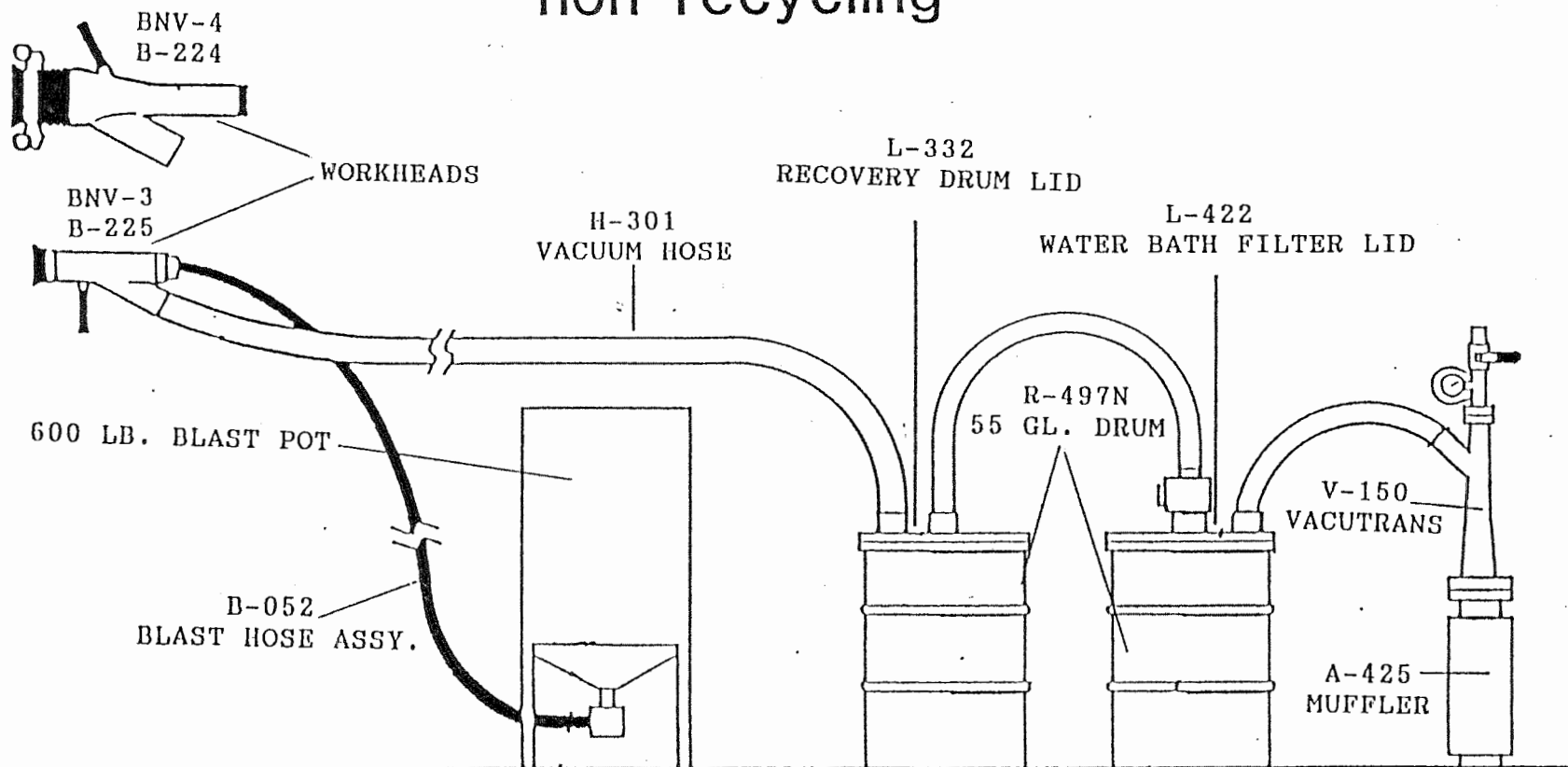

DIAGRAM 1

# BNVS-305 SINGLE VACUTRANS BLAST N' VAC SYSTEM recycling

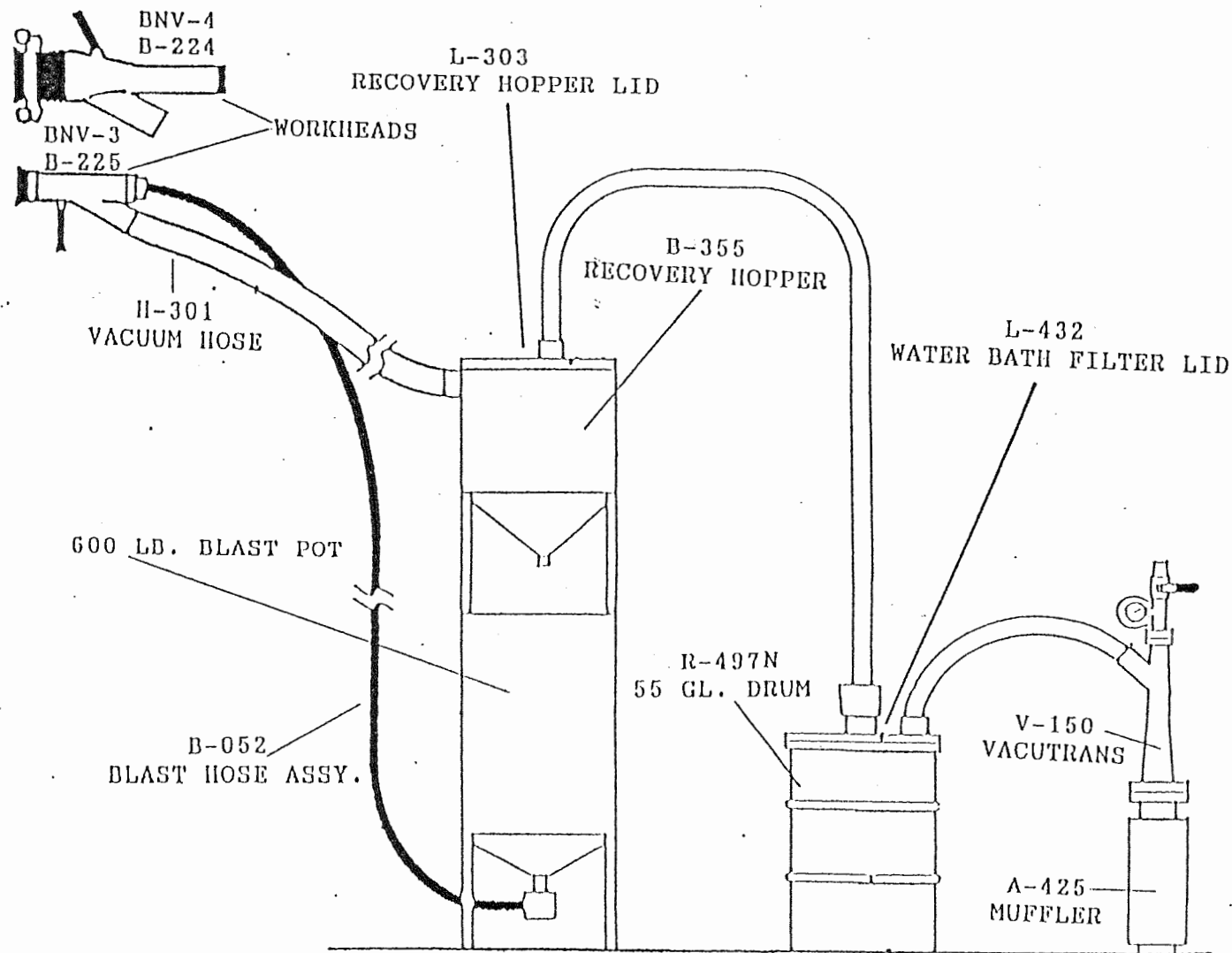
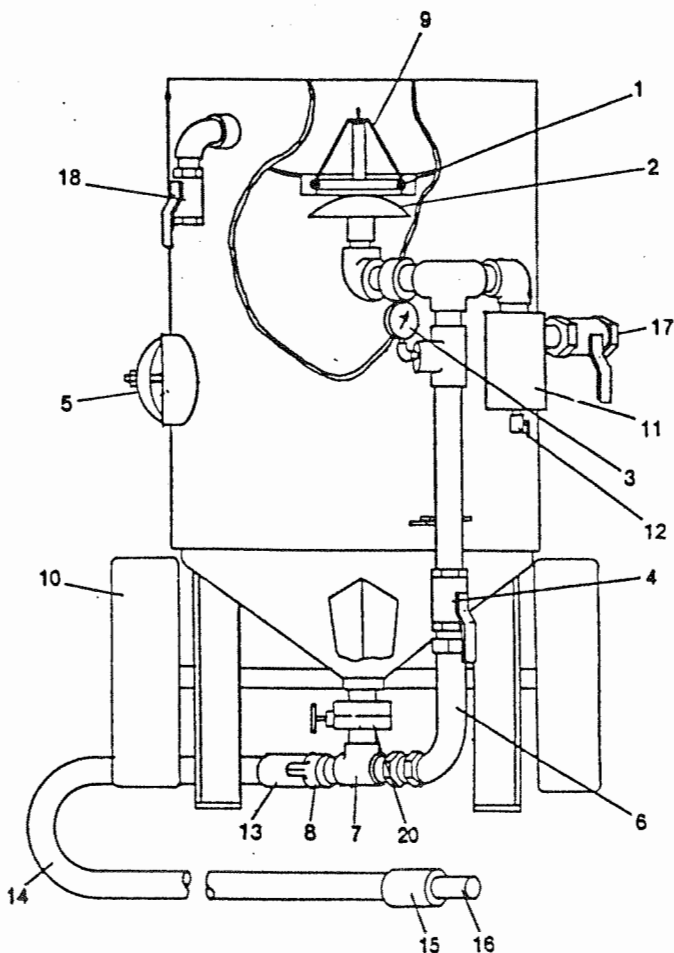
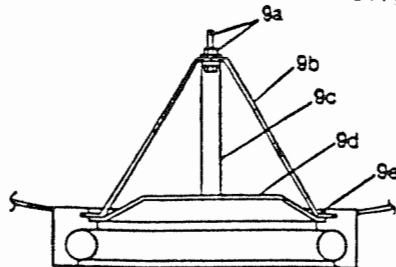

DIAGRAM 2

# Figure 1 SUPERBLAST WITH MANUAL CONTROLS



1. 523872 Huber U Ring—o
2. 525072 Sealing Plunger—Coated 8"
3. 550242 Pressure Gauge—1/4" NPT
4. 517442 Air Valve (brass) with handle—1" NPT (SuperBlast-350)  
517452 Air Valve (brass) with handle—1 1/4" NPT (SuperBlast-650 and larger)
- 504352 Replaceable Handle (with right angle stop tab) for 1" Valve  
505272 Replaceable Handle (with right angle stop tab) for 1 1/4" Valve  
507132 Replaceable Handle (with straight stop tab) for 1" Valve  
507142 Replaceable Handle (with straight stop tab) for 1 1/4" Valve
5. Inspection Door Assembly (wedge)  
Inspection Door Assembly (clevis)  
524152 Door Gasket
6. 520922 Flexible Hose Assembly SuperBlast 350 (Prior to 5/1/84)  
290318 Flexible Hose Assembly SuperBlast 350 (After to 5/1/84)  
521022 Flexible Hose Assembly SuperBlast 650 (Prior to 5/1/84)  
290319 Flexible Hose Assembly SuperBlast 650 (After 5/1/84)  
521062 Flexible Hose Assembly SuperBlast 1050 (Prior to 5/1/84)  
290333 Flexible Hose Assembly SuperBlast 1050 (After 5/1/84)
7. 545752 1 1/4" x 1 1/4" x 2" Tee
8. 753262 Tank Coupling—Aluminum  
753272 Tank Coupling—Brass
9. 290387 E-Z Fill Bag Breaker/Screen, Complete
- 9a. 552112 Bolt with Lock Washer and Nut
- 9b. 782972 Top Legs
- 9c. 782982 Bottom Legs
- 9d. 782992 Screen
- 9e. 551372 Screw
10. 505082 Wheel—12" Semi Pneumatic—(SuperBlast-350)  
505072 Wheel—18" Semi Pneumatic—(SuperBlast-650 and larger)
11. 290191 DF-1 Dry-Flo Manual Drain Separator—1" NPT with built-in check (Not supplied with Gauge or Drain Valve)  
290192 Df-Dry-Flo Manual Drain Separator—1 1/4" NPT with built-in check (Not supplied with Gauge or Drain Valve.)
- 504562 ADS-1 Automatic Drain Separator—1" NPT (Not supplied with gauge)  
504662 ADS-2 Automatic Drain Separator—1 1/4" NPT (Not supplied with gauge)
12. 518252 Drain Valve—1/4" NPT
13. \*\* Blast Hose Coupling
14. \*\* Blast Hose
15. \*\* Nozzle Coupling
16. \*\* Nozzle
17. Air Valve (brass) with handle—1" NPT (SuperBlast-350)  
517452 Air Valve (brass) with handle—1 1/4" NPT (SuperBlast-650 and larger)
- 504352 Replaceable Handle (with right angle stop tab) for 1" Valve  
505272 Replaceable Handle (with right angle stop tab) for 1 1/4" Valve  
507132 Replaceable Handle (with straight stop tab) for 1" Valve  
507142 Replaceable Handle (with straight stop tab) for 1 1/4" Valve
18. 517442 Air Valve (brass) with Handle  
504352 Replaceable Handle for 1" Valve

Figure 2  
SuperBlast with Saf-Stop II, 780 Series  
Pneumatic Remote Controls Installed

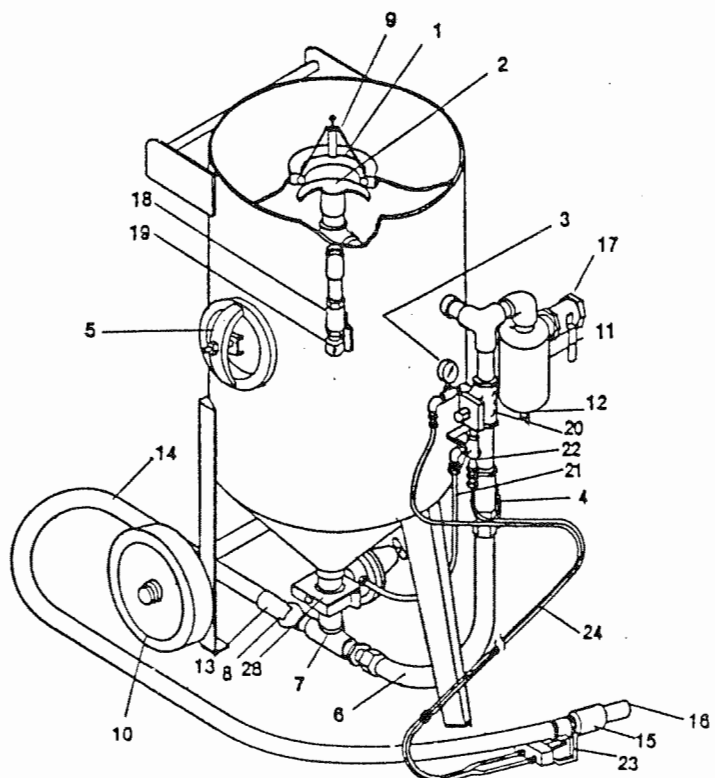

\*\*\*\* YOUR BLAST MACHINE IS EQUIPPED WITH THE 780 SERIES GRIT VALVE AS DEPICTED IN THE DRAWING AT THE RIGHT BOTTOM CORNER OF THIS PAGE \*\*\*\*

Parts 1. through 19. same as Figure 1

20. 518052 1" Automatic Air Valve (SuperBlast 350)  
518062 1 1/4" Automatic Air Valve (SuperBlast 650, 1050)
21. 290371 Control Hose (1/4") w/fittings installed (350)  
290373 Control Hose (1/4") w/fittings installed (650)  
290375 Control Hose (1/4") w/fittings installed (1050)
22. 520642 Shut-Off Valve
23. B-556 Remote Control Switch  
Dual Line (See Fig. 8 for parts)
24. 521962 Dual Line Hose, 30' w/fittings installed  
521882 Dual Line Hose, 50' w/fittings installed  
521892 Dual Line Hose, 55' w/fittings installed



FIGURE 3  
SYSTEM VALVE REFERENCE GUIDE

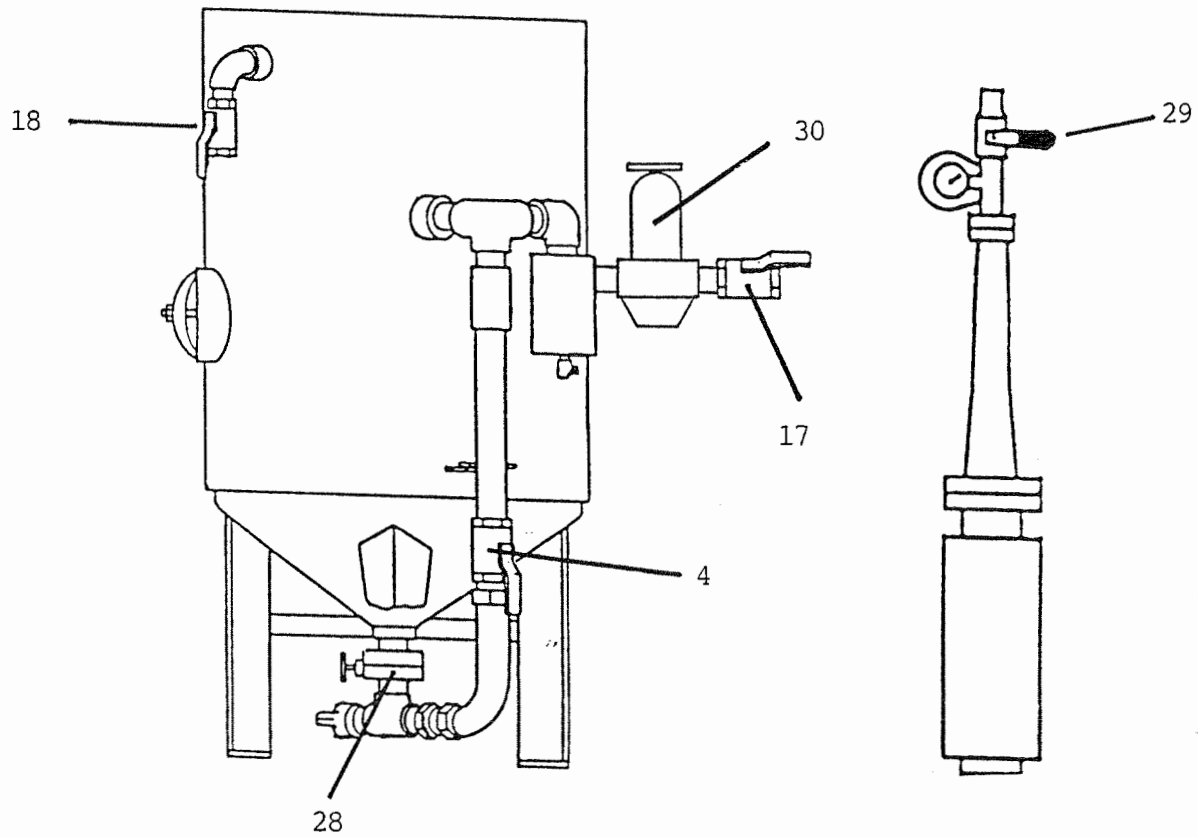

- 28 - GRIT VALVE
- 18 - EXHAUST VALVE (DEPRESSURIZATION)
- 17 - BLAST POT AIR SUPPLY
- 4 - CHOKE VALVE (FOR CLEARING POT OF ABRASIVE OR OBSTRUCTIONS-NORMALLY OPEN)
- 29 - VACUTRANS AIR SUPPLY
- 30 - PRESSURE REGULATOR

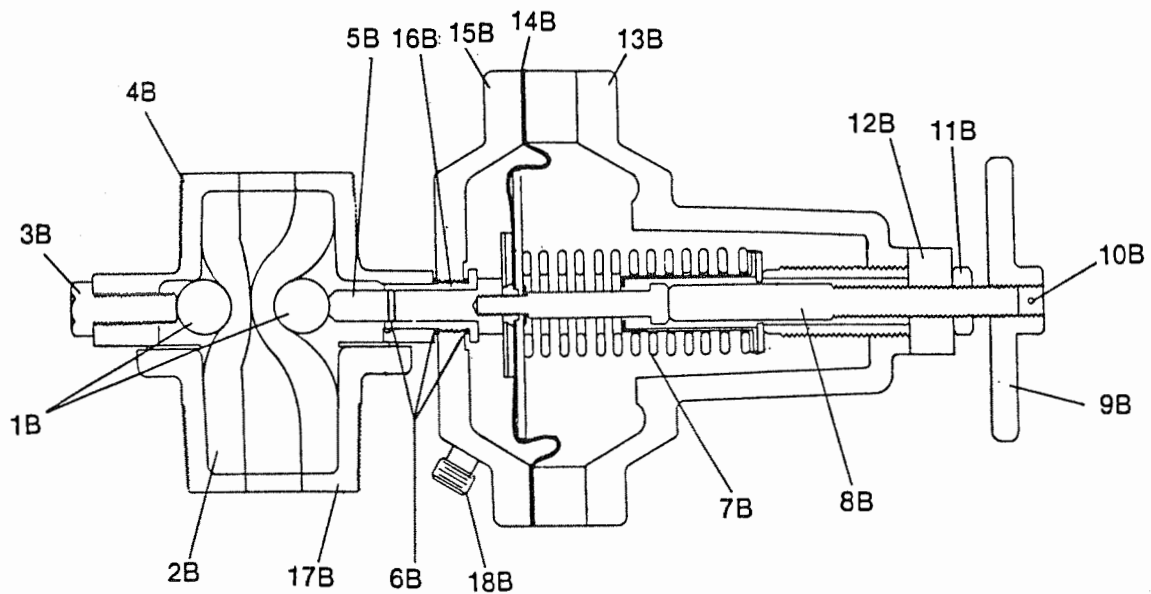

- |    |        |                  |     |        |                    |
|----|--------|------------------|-----|--------|--------------------|
| 1B | 753632 | Pinch Roller     | 10B | 551732 | N.Y. Loc Set Screw |
| 2B | 525802 | Metering Tube    | 11B | 552672 | 1/2" Jam Nut       |
| 3B | 552222 | Bolt             | 12B | 505832 | Spring Tensioner   |
| 4B | 753692 | Valve Body       | 13B | 753682 | Spring Enclosure   |
| 5B | 505872 | Plunger w/o Ring | 14B | 525012 | Diaphragm          |
| 6B | 561422 | "O" Ring         | 15B | 753112 | Diaphragm Cover    |
| 7B | 290296 | Spring Assembly  | 16B | 753462 | Plunger Guide      |
| 8B | 505812 | Handle Shaft     | 17B | 753292 | Upper Flange       |
| 9B | 753622 | Handle           | 18B | 520222 | Hose Adapter       |

Figure 4 AUTOMATIC HIGH PERFORMANCE SURE-FLO [INTERNAL PARTS]

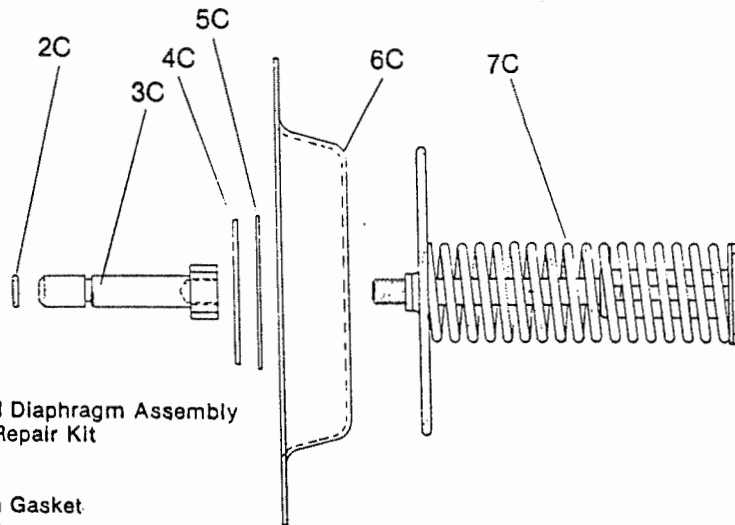

- |    |        |                               |
|----|--------|-------------------------------|
| 1C | 290296 | Spring and Diaphragm Assembly |
| 2C | 561422 | "O" Ring Repair Kit           |
| 3C | 505872 | Plunger                       |
| 4C | 552902 | Washer                        |
| 5C | 525002 | Diaphragm Gasket              |
| 6C | 525012 | Diaphragm                     |
| 7C | 290306 | Spring Assembly               |

Figure 5 AUTOMATIC SURE-FLO [SPRING AND DIAPHRAGM ASSEMBLY]

FIGURE 6

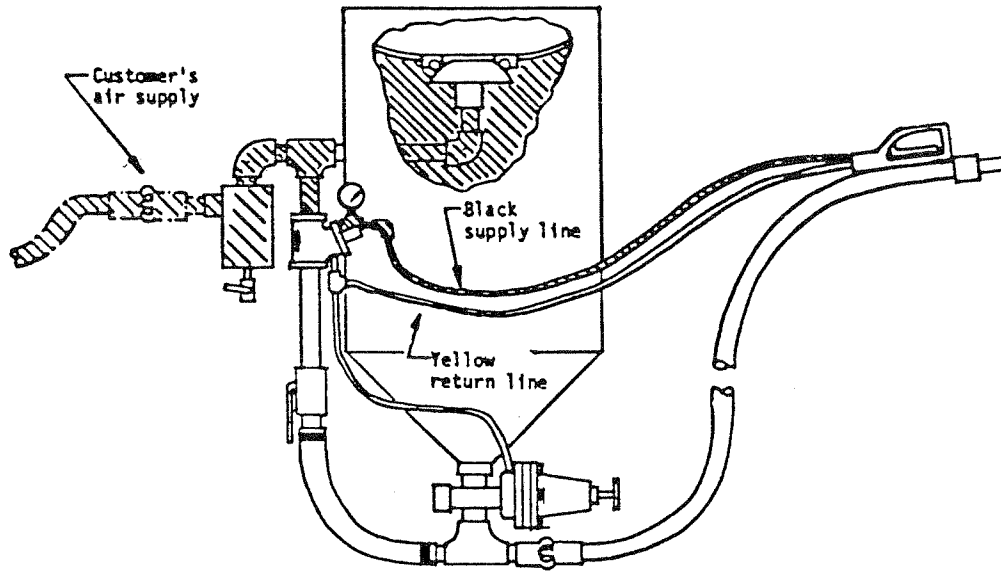

NON-BLASTING MODE  
Shaded areas are pressurized

Air flow in a pneumatic remote controlled blaster in both the blasting and non-blasting modes.

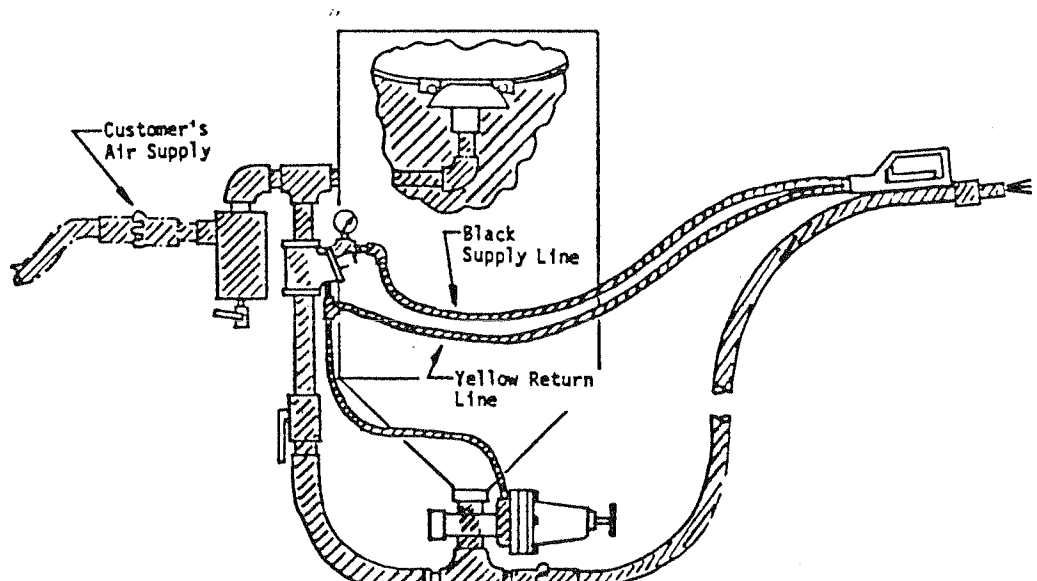

BLASTING MODE  
Shaded areas are pressurized

# BNV-3 WORKHEAD COMPONENTS

FIGURE 7

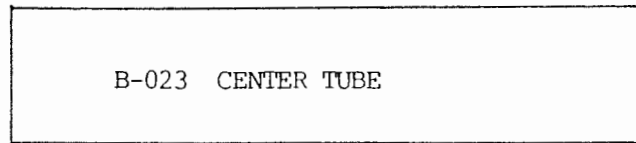

B-023 CENTER TUBE

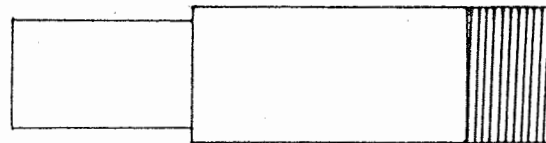

B-104 BLAST NOZZLE

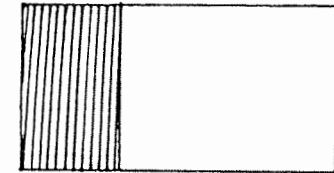

B-201 NOZZLE HOLDER

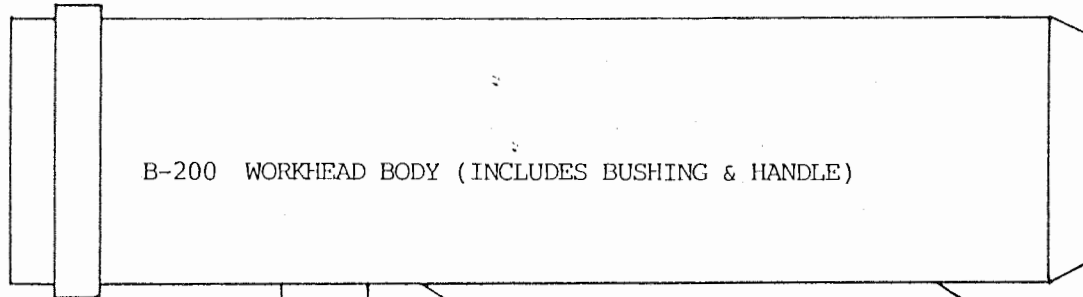

B-200 WORKHEAD BODY (INCLUDES BUSHING & HANDLE)

REFER TO  
ATTACHED  
SHEET FOR  
BRUSH SETS

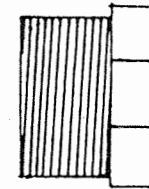

B-040  
BLAST NOZZLE  
HOLDER BUSHING

B-025  
HANDLE

CONSUMABLE PARTS FOR THIS WORKHEAD INCLUDE THE BRUSHES OUTLINED ON THE FOLLOWING SHEET AND THE B-023 CENTER TUBE. AN INNER BRUSH SHOULD LAST 2-3 HOURS OF BLAST TIME AND THE CENTER TUBE SHOULD LAST 4-6 HOURS. OUTER BRUSH USAGE WILL BE AT A FRACTION OF INNER BRUSH RATES DEPENDING ON OPERATOR.

# BNV-3 BRUSH SET USE GUIDE

FIGURE 8

FOR USE ON  
FLAT SURFACES

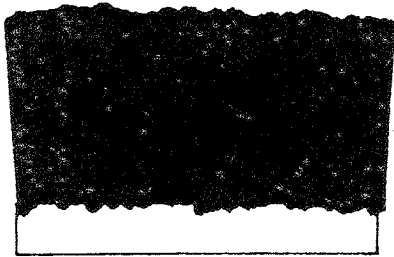

B-255  
FLAT INNER BRUSH

FOR USE ON  
OUTSIDE 90°  
CORNERS

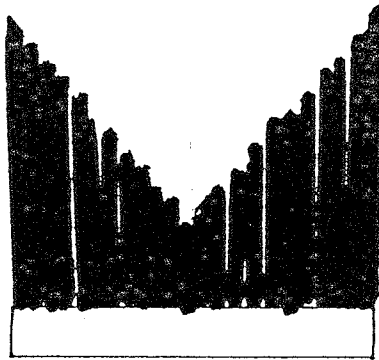

B-2705  
OUTSIDE CORNER BRUSH SET

FOR USE ON  
INSIDE 90°  
CORNERS

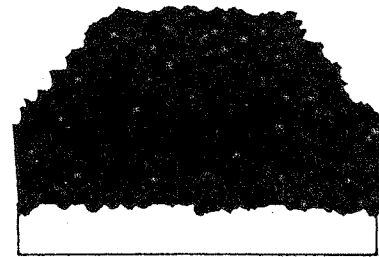

B-2605  
INSIDE CORNER BRUSH SET



B-250  
FLAT OUTER BRUSH

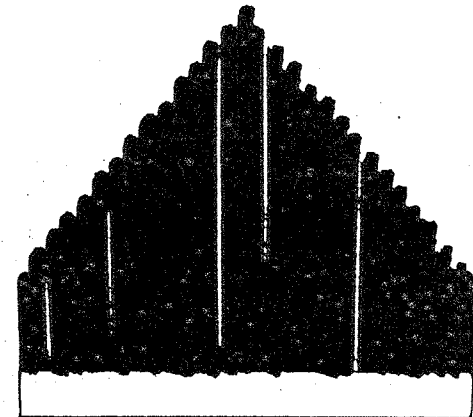
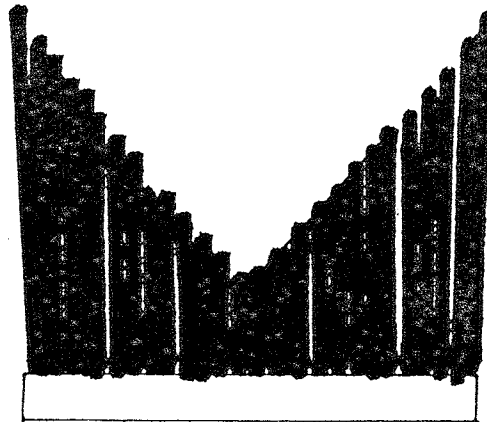

# BNV-4 AND BNV-6 WORKHEAD COMPONENTS

FIGURE 9

20

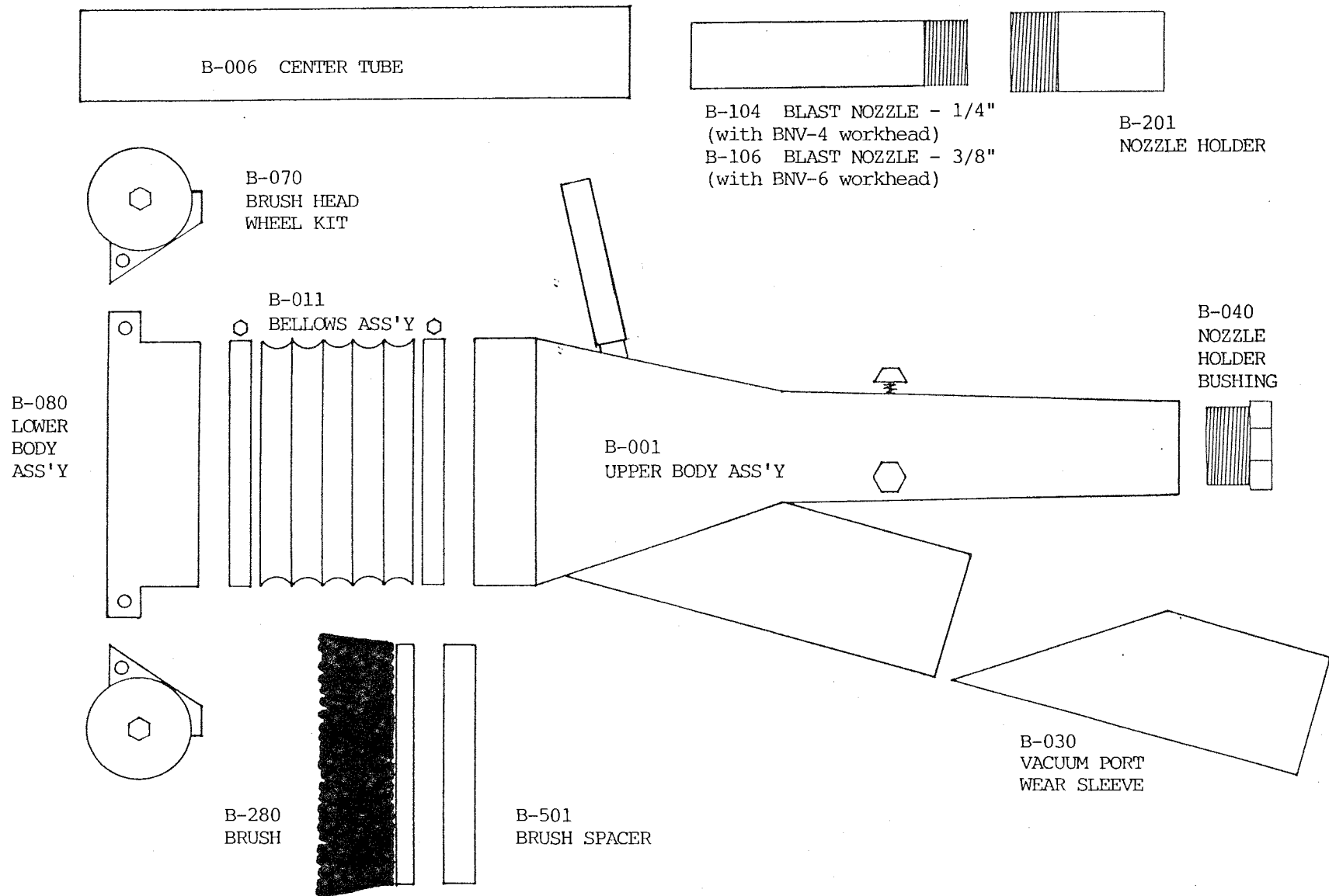

## PARTS BREAKDOWN

| <u>PART NUMBER</u> | <u>DESCRIPTION</u>  |
|--------------------|---|
| B-100              | COMPLETE BODY ASSEMBLY - INCLUDES ALL PARTS ON DIAGRAM EXCEPT B-104 OR B-106 BLAST NOZZLE   |
| B-001              | UPPER BODY ASSEMBLY - INCLUDES B-040 BUSHING AND 3 THUMBSCREWS FOR HOLDING CENTER TUBE IN PLACE AND B-030 VACUUM PORT WEAR SLEEVE |
| B-080              | LOWER BODY ASSEMBLY INCLUDING GIMBLE RING AND MISC HARDWARE NOT SHOWN ON DRAWING  |
| B-011              | BELLOWS ASSEMBLY INCLUDING TWO CLAMPS   |
| B-006              | CENTER TUBE   |
| B-070              | BRUSH HEAD WHEEL KIT - INCLUDES WHEEL MOUNT BRACKETS, TENSION SPRINGS, ADJUSTING BOLT, AXLES AND WHEELS                           |
| B-280              | BRUSH   |
| B-501              | BRUSH SPACER  |
| B-030              | VACUUM PORT WEAR SLEEVE   |
| B-040              | PVC BUSHING - 2" x 1½"  |
| B-201              | NOZZLE HOLDER   |

CONSUMABLE PARTS ON THIS WORKHEAD INCLUDE THE B-280 BRUSH WHICH SHOULD 2-3 HOURS OF BLAST TIME AND THE B-006 CENTER TUBE WHICH SHOULD LAST ABOUT 4-6 HOURS OF BLAST TIME.

FIGURE 11

PRESSURE REGULATOR BREAKDOWN

Maximum Pressure 300 PSI—Temp. Range 40° to 120° F

**Installation**

Before installing, blow out pipe line to remove scale and other foreign matter. This unit has DRYSEAL pipe threads; use pipe compound or tape sparingly to male threads only. Install regulator in pipe line so that air will flow from IN to OUT and as near as possible to equipment being supplied. Connections R and L are normally for gauge use but may be used for outlet purposes. To insure trouble-free performance, a filter should be installed upstream of the regulator.

**Adjustment**

Clockwise turning of the adjusting screw increases the reduced or regulated pressure. With relieving-type regulators the reduced pressure follows adjustment of the screw, with non-relieving regulators adjustment for lower reduced pressure will not be obtained until the reduced pressure system is "bled off" or until air flow starts.

**Maintenance**

If the air supply is kept clean, the regulator should provide long periods of uninterrupted service. Erratic regulator operation or loss of regulation is most always due to dirt in the disc area and cleaning is in order.

**Cleaning**

Depressurize regulator, remove bottom plug, spring, and disc. Clean parts with denatured alcohol, wipe off seat and blow out body with compressed air. Reassemble parts as a unit and screw into regulator—before tightening bottom plug make sure disc is in center hole in body. Should regulator continue to malfunction, obtain repair kit and replace parts indicated below.

**REPLACEMENT PARTS**  
Order by Repair Kit Number

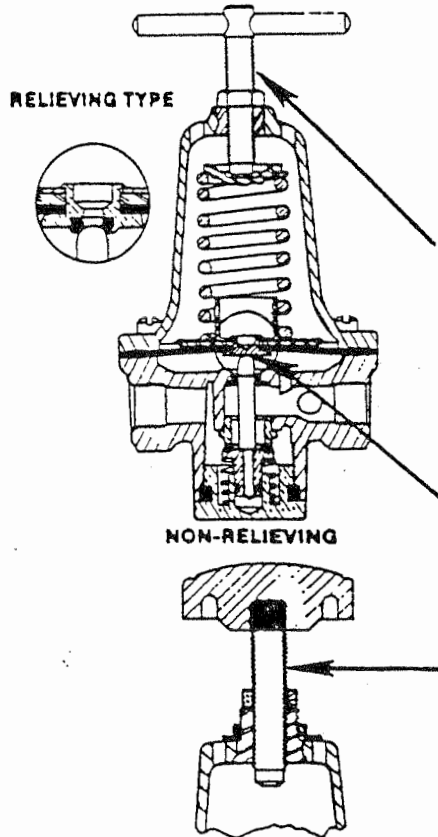

| KIT NAME                    | KIT NO. | SIZE             | TEE HANDLE ASSY. | CHECK NUT | DIAPHRAGM ASSY. | DISC ASSY. | BOTTOM PLUG GASKET | ADJUSTING SCREW & RUBBER ASSY. | CHECK NUT | PANEL MOUNTING NUT | PANEL MOUNTING WASHER |
|-----------------------------|---------|------------------|------------------|-----------|-----------------|------------|--------------------|--------------------------------|-----------|--------------------|-----------------------|
| TEE HANDLE REPLACEMENT KIT  | TK16Y   | 1/4" & 3/8"      | ●                | ●         |                 |            |                    |                                |           |                    |                       |
|                             | TK119A  | 1/2"             | ●                | ●         |                 |            |                    |                                |           |                    |                       |
|                             | RK119B  | 3/4" thru 1 1/2" | ●                | ●         |                 |            |                    |                                |           |                    |                       |
| REPAIR KIT RELIEVING        | RK119Y  | 1/4" & 3/8"      |                  |           | ●               | ●          | ●                  |                                |           |                    |                       |
|                             | RK119A  | 1/2"             |                  |           | ●               | ●          | ●                  |                                |           |                    |                       |
|                             | RK119B  | 3/4" & 1"        |                  |           | ●               | ●          | ●                  |                                |           |                    |                       |
| REPAIR KIT NON-RELIEVING    | RK119D  | 1 1/4" & 1 1/2"  |                  |           | ●               | ●          | ●                  |                                |           |                    |                       |
|                             | RK118Y  | 1/4" & 3/8"      |                  |           | ●               | ●          | ●                  |                                |           |                    |                       |
| REPAIR KIT NON-RELIEVING    | RK118A* | 1/2"             |                  |           | ●               | ●          | ●                  |                                |           |                    |                       |
|                             | RK118B  | 3/4" & 1"        |                  |           | ●               | ●          | ●                  |                                |           |                    |                       |
|                             | RK118D  | 1 1/4" & 1 1/2"  |                  |           | ●               | ●          | ●                  |                                |           |                    |                       |
| PANEL MOUNT REPLACEMENT KIT | PK16Y   | 1/4" to 1/2"     |                  |           |                 |            |                    | ●                              | ●         | ●                  | ●                     |



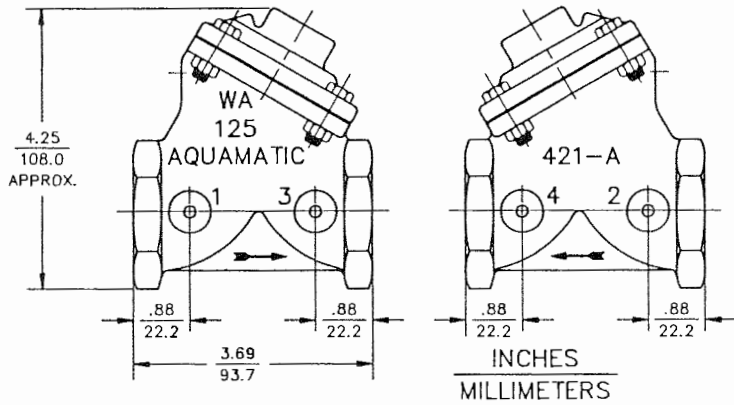

- NOTE:
1. AMERICAN NATIONAL STANDARD TAPER PIPE THREADS (N.P.T.) PER ANSI B2.1-1968.
  2. VALVES AVAILABLE WITH B.S.P. END CONNECTIONS PER BS 21:1973.
  3. ETH. PROP. DENOTES ETHYLENE PROPYLENE (MATERIAL).
  4. T.C. DENOTES MATERIAL IS TEFLON COATED.

MAXIMUM WORKING PRESSURE (P.S.I.)  
PER MSS SP88 CLASS, CATEGORY B

| SERIES | TEMPERATURE (°F.) |     |     |     |
|--------|-------------------|-----|-----|-----|
|        | 150               | 200 | 250 | 300 |
| 421    | 200               | 175 | 165 | 150 |

SEE SHEET 421A  
FOR OPTIONS

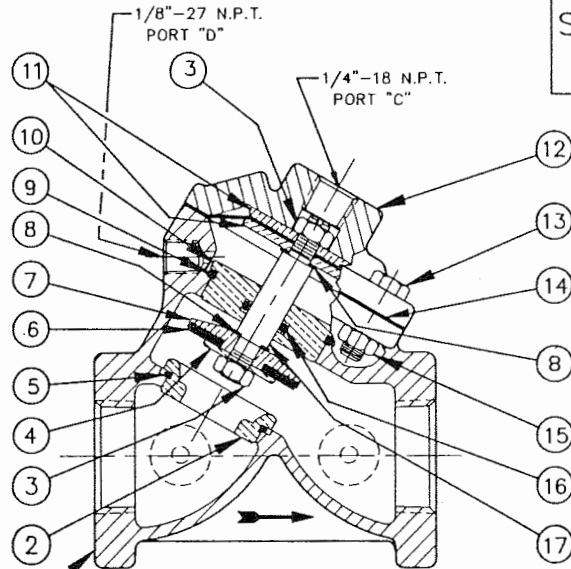

421DV3 (3/4 N.P.T.)  
421DV4 (1" N.P.T.)  
NORMALLY OPEN (STANDARD)

"NORMALLY OPEN" (POWER TO CLOSE) - LINE PRESSURE/FLOW AGAINST THE VALVE SEATING DISC WILL OPEN THE VALVE. CONTROL PRESSURE APPLIED TO THE TOP OF THE DIAPHRAGM WILL CLOSE THE VALVE. (CONTROL PRESSURE SHOULD BE APPLIED AT PORT "C").

| ASSEMBLY TOOLS |          |
|----------------|----------|
| ITEM NO.       | TOOL NO. |
| 2              | 421-MT   |
| 10             | 421-GT   |

| NO. | DESCRIPTION                                   | STD.           | PART NO.      | QTY.   | MAT. DES. |     |
|-----|---|----------------|---------------|--------|-----------|-----|
| 1   | BODY  | CAST IRON      | 3/4" N.P.T. * | 421-A3 | 1         | M1  |
|     |   |                | 1" N.P.T. *   | 421-A4 |           |     |
|     | CAST BRASS                                    | 3/4" N.P.T.    | 421-AB3       | M7     |           |     |
|     |   | 1" N.P.T.      | 421-AB4       |        |           |     |
| 2   | SEAT  | CAST BRASS *   | 421-M         | 1      | M7        |     |
|     | (SEE ASSEMBLY TOOLS BELOW)                    | CAST STN. STL. | 421-MS        | 1      | M3        |     |
| 3   | HEX LOCK NUT (1/4-28)                         | *              | NUS-0010      | 2      | M25       |     |
| 4   | DISC PLATE                                    | BRASS *        | 421-K         | 1      | M49       |     |
|     |   | STN. STL.      | 421-KS        |        | M17       |     |
| 5   | O-RING  | BUNA N *       | ORB-024       | 1      | E2        |     |
|     |   | ETH. PROP.     | ORE-024       |        | E3        |     |
|     |   | VITON          | ORV-024       |        | E4        |     |
|     |   | BUNA N *       | 421-J         |        | E2        |     |
| 6   | DISC  | ETH. PROP.     | 421-JE        | 1      | E3        |     |
|     |   | VITON          | 421-JV        |        | E4        |     |
|     |   | BRASS *        | 421-H         |        | 1         | M13 |
|     |   | STN. STL.      | 421-HS        |        |           | M17 |
| 8   | GASKET  | COPPER *       | 200-GG        | 2      | M50       |     |
|     |   | LEAD ALLOY     | 200-GGL       |        | M38       |     |
| 9   | O-RING  | BUNA N *       | ORB-125       | 1      | E2        |     |
|     |   | ETH. PROP.     | ORE-125       |        | E3        |     |
|     |   | VITON          | ORV-125       |        | E4        |     |
| 10  | O-RING RETAINER<br>(SEE ASSEMBLY TOOLS BELOW) | BRASS *        | 421-G         | 1      | M13       |     |
|     |   | STN. STL.      | 421-GS        |        | M17       |     |
| 11  | DIAPHRAGM PLATE                               | BRASS *        | 421-D         | 2      | M49       |     |
|     |   | STN. STL.      | 421-DS        |        | M17       |     |
| 12  | CAP   | CAST IRON *    | 421-C         | 1      | M1        |     |
|     |   | CAST BRASS     | 421-CB        |        | M7        |     |
| 13  | HEX HD. CAP SCREW (1/4-20 X 7/8)              | *              | SCZ-0004      | 4      | M39       |     |
| 14  | DIAPHRAGM                                     | BUNA N/NYLON * | 421-FB        | 1      | D1        |     |
|     |   | VITON/NOMEX    | 421-FV        |        | D2        |     |
| 15  | HEX NUT (1/4-20)                              | *              | NUZ-0008      | 4      | M39       |     |
| 16  | O-RING  | BUNA N *       | ORB-110TC     | 1      | E2A       |     |
|     |   | ETH. PROP.     | ORE-110       |        | E3        |     |
|     |   | VITON          | ORV-110       |        | E4        |     |
| 17  | SHAFT   | *              | 421-L         | 1      | M17B      |     |

REPAIR PARTS KITS

| DESCRIPTION   | PART NO.                       |                                 |                                 |
|---|--------------------------------|---------------------------------|---------------------------------|
|   | BUNA N                         | ETH. PROP.                      | VITON                           |
| DIAPHRAGM & SEALS KIT<br>CONSISTS OF ITEM NOS.<br>3, 5, 6, 8, 9, 14 & 16  | 421-RA<br>(INCLUDES<br>421-FB) | 421-RAE<br>(INCLUDES<br>421-FB) | 421-RAV<br>(INCLUDES<br>421-FV) |
| INTERNAL PARTS KIT<br>NORMALLY OPEN MODEL<br>CONSISTS OF STANDARD (*)<br>ITEM NOS. 4, 7, 10, 11, 17<br>AND APPROPRIATE<br>"DIAPHRAGM AND SEALS KIT"               | 421-RB                         | 421-RBE                         | 421-RBV                         |
| INTERNAL PARTS KIT<br>NORMALLY CLOSED MODEL<br>CONSISTS OF STANDARD (*)<br>ITEM NOS. 4,7,10,11,23(SEE SHEET 421A)<br>AND APPROPRIATE<br>"DIAPHRAGM AND SEALS KIT" | 421-RC                         | 421-RCE                         | 421-RCV                         |

**AquaMatic®**  
AQUAMATIC, INC.  
ROCKFORD, ILLINOIS

SERIES 421 STANDARD MODEL  
DIAPHRAGM VALVE (3/4" & 1" N.P.T.)

| SCALE | DRAWN DATE | DWC. NO.  | REV. |
|-------|------------|-----------|------|
| MM    | 9-15-88    | C-421-148 | 2    |

REVISED ON 5-3-90 (ECN-0095)