



Pro-Finish® Cabinet Models

Pro-Finish® Cabinets (Pressure Systems)

MODEL DESCRIPTION	PART NUMBER	NUMBER OF DOORS	DUST COLLECTION	BLOWER MOTOR	SHIPPING WEIGHT
2636 PR-4	142101	1 standard	—	—	615 lbs
2636 PRB-4	102100	1 standard	Dust bag	1 hp	664 lbs
2636 PRC-4	102101	1 standard	DCM-80A	1 hp	914 lbs
2636 PR-6	142142	1 standard	—	—	630 lbs
2636 PRC-6	102142	1 standard	DCM-200	1 hp	1345 lbs
2636 PRC-6, CDC	102148	1 standard	CDC-6	1½ hp	1465 lbs
3648 PR-4	143101	2 standard	—	—	735 lbs
3648 PRB-4	103100	2 standard	Dust bag	1 hp	782 lbs
3648 PRC-4	103101	2 standard	DCM-80A	1 hp	1032 lbs
3648 PR-6	143121	2 standard	—	—	750 lbs
3648 PRC-6	103121	2 standard	DCM-200	1½ hp	1479 lbs
3648 PRC-6, CDC	103151	2 standard	CDC-6	1½ hp	1779 lbs
3648 PR-9	134121	2 standard	—	—	785 lbs
3648 PRC-9	103124	2 standard	DCM-200A	2 hp	1515 lbs
3648 PRC-9, CDC	103152	2 standard	CDC-9	2 hp	1815 lbs
3660 PR-6	146102	2 standard	—	—	1180 lbs
3660 PRC-6	126101	2 standard	DCM-200	1½ hp	1910 lbs
3660 PRC-6, CDC	126151	2 standard	CDC-6	1½ hp	2030 lbs
3660 PR-9	146121	2 standard	—	—	1215 lbs
3660 PRC-9	126121	2 standard	DCM-200A	2 hp	1945 lbs
3660 PRC-9, CDC	126152	2 standard	CDC-9	2 hp	2065 lbs
3674 PRC-9	128121	2 standard	DCM-200A	2 hp	1970 lbs
3674 PRC-9, CDC	128151	2 standard	CDC-9	2 hp	2290 lbs
3696 TWIN PRB-4	106100	2 standard	(2) Dust bags	(2) 1 hp	1379 lbs
3696 TWIN PRC-4	106101	2 standard	(2) DCM-80A	(2) 1 hp	1879 lbs
3696 TWIN PRC-6	106121	2 standard	(2) DCM-200	(2) 1½ hp	2773 lbs
3696 TWIN PRC-6, CDC	106151	2 standard	(2) CDC-6	(2) 1½ hp	3373 lbs
4848 PR-6	144101	2 standard	—	—	910 lbs
4848 PRC-6	104101	2 standard	DCM-200	1½ hp	1636 lbs
4848 PRC-6, CDC	104151	2 standard	CDC-6	1½ hp	1936 lbs
4848 PR-9	144121	2 standard	—	—	940 lbs
4848 PRC-9	104121	2 standard	DCM-200A	2 hp	1671 lbs
4848 PRC-9, CDC	104152	2 standard	CDC-9	2 hp	1791 lbs
6060 PR-9	145101	2 standard	—	—	1219 lbs
6060 PRC-9	105101	2 standard	DCM-200A	2 hp	1949 lbs
6060 PRC-9, CDC	105151	2 standard	CDC-9	2 hp	2069 lbs
60120 TWIN PRC-9	107101	2 standard	DCM-200A	(2) 2 hp	3713 lbs
60120 TWIN PRC-9, CDC	107151	2 standard	CDC-9	(2) 2 hp	4313 lbs
7272 PRC-9	127101	1 standard	DCM-200A	2 hp	2900 lbs
7272 PRC-12	127123	1 standard	DCM-200B	5 hp	3000 lbs



Options: Pro-Finish® Systems

Pro-Finish® Cabinets (Suction Systems)

MODEL DESCRIPTION	PART NUMBER	NUMBER OF DOORS	DUST COLLECTION	BLOWER MOTOR	SHIPPING WEIGHT
2636 S	142011	1 standard	—	—	370 lbs
2636 SB	102010	1 standard	Dust bag	1 hp	421 lbs
2636 SC	102011	1 standard	DCM-80A	1 hp	671 lbs
2636 SR-4	142001	1 standard	—	—	400 lbs
2636 SRB-4	102000	1 standard	Dust bag	1 hp	451 lbs
2636 SRC-4	102001	1 standard	DCM-80A	1 hp	701 lbs
2636 SR-6	142021	1 standard	—	—	440 lbs
2636 SRC-6	102021	1 standard	DCM-200	1½ hp	1130 lbs
2636 SRC-6, CDC	102041	1 standard	CDC-6	1½ hp	1250 lbs
3648 S	143011	2 standard	—	—	490 lbs
3648 SB	103010	2 standard	Dust bag	1 hp	539 lbs
3648 SC	103011	2 standard	DCM-80A	1 hp	789 lbs
3648 SR-4	143001	2 standard	—	—	520 lbs
3648 SRB-4	103000	2 standard	Dust bag	1 hp	565 lbs
3648 SRC-4	103001	2 standard	DCM-80A	1 hp	819 lbs
3648 SR-6	143021	2 standard	—	—	560 lbs
3648 SRC-6	103021	2 standard	DCM-200	1½ hp	1266 lbs
3648 SRC-6, CDC	103051	2 standard	CDC-6	1½ hp	1575 lbs
3648 SR-9	143022	2 standard	—	—	750 lbs
3648 SRC-9	103131	2 standard	DCM-200A	2 hp	1300 lbs
3648 SRC-9, CDC	103132	2 standard	CDC-9	2 hp	1610 lbs
3660 S	146011	2 standard	—	—	940 lbs
3660 SC	126011	2 standard	DCM-200	1½ hp	1670 lbs
3660 SR-6	146001	2 standard	—	—	965 lbs
3660 SRC-6	126001	2 standard	DCM-200	1½ hp	1695 lbs
3660 SRC-6, CDC	126051	2 standard	CDC-6	1½ hp	1815 lbs
3660 SR-9	146021	2 standard	—	—	1000 lbs
3660 SRC-9	126021	2 standard	DCM-200A	2 hp	1730 lbs
3660 SRC-9, CDC	126052	2 standard	CDC-9	2 hp	1850 lbs
3674 SRC-9	128021	2 standard	DCM-200A	2 hp	1760 lbs
3674 SRC-9 (CDC)	128051	2 standard	CDC-9	2 hp	2060 lbs
3696 TWIN SB	106010	2 standard	(2) Dust bags	(2) 1 hp	1078 lbs
3696 TWIN SC	106011	2 standard	(2) DCM-80A	(2) 1 hp	1578 lbs
3696 TWIN SRB-4	106000	2 standard	(2) Dust bags	(2) 1 hp	1138 lbs
3696 TWIN SRC-4	106001	2 standard	(2) DCM-80A	(2) 1 hp	1638 lbs
3696 TWIN SRC-6	106021	2 standard	(2) DCM-200	(2) 1½ hp	2632 lbs
3696 TWIN SRC-6, CDC	106051	2 standard	(2) CDC-6	(2) 1½ hp	3232 lbs
4848 S	144011	2 standard	—	—	670 lbs
4848 SC	104011	2 standard	DCM-200	1½ hp	1400 lbs
4848 SR-6	144001	2 standard	—	—	695 lbs
4848 SRC-6	104001	2 standard	DCM-200	1½ hp	1423 lbs
4848 SRC-6, CDC	104051	2 standard	CDC-6	1½ hp	1545 lbs
4848 SR-9	144021	2 standard	—	—	730 lbs
4848 SRC-9	104021	2 standard	DCM-200A	2 hp	1458 lbs
4848 SRC-9, CDC	104052	2 standard	CDC-9	2 hp	1580 lbs
6060 S	145011	2 standard	—	—	939 lbs
6060 SC	105011	2 standard	DCM-200A	2 hp	1669 lbs
6060 SR-9	145001	2 standard	—	—	1006 lbs
6060 SRC-9	105001	2 standard	DCM-200A	2 hp	1736 lbs
6060 SRC-9, CDC	105051	2 standard	CDC-9	2 hp	1856 lbs
60120 TWIN SC	107011	2 standard	DCM-200A	(2) 2 hp	3338 lbs
60120 TWIN SRC-9	107001	2 standard	DCM-200A	(2) 2 hp	3472 lbs
60120 TWIN SRC-9, CDC	107051	2 standard	CDC-9	(2) 2 hp	4072 lbs
7272 SRC-9	127001	1 standard	DCM-200A	2 hp	2700 lbs
7272 SRC-12	127023	1 standard	DCM-200B	5 hp	2800 lbs



Pro-Finish® Cabinet Models

Ergo-Blast Cabinets (Pressure Systems)

MODEL DESCRIPTION	PART NUMBER	NUMBER OF DOORS	DUST COLLECTION	BLOWER MOTOR	SHIPPING WEIGHT
ERGO 2636 PRC-4	120101	1 standard	DCM-80A	1 hp	1015 lbs
ERGO 3648 PRC-4	121101	2 standard	DCM-80A	1 hp	1130 lbs
ERGO 3648 PRC-6	121121	2 standard	DCM-200	1½ hp	1585 lbs
ERGO 3648 PRC-6, CDC	121151	2 standard	CDC-6	1½ hp	1885 lbs
ERGO FaStrip® 3648 PRC-6	121921	2 standard	DCM-200	1½ hp	1600 lbs
ERGO FaStrip® 3648 PRC-6, CDC	121951	2 standard	CDC-6	1½ hp	1900 lbs
ERGO 3660 PRC-6	123101	2 standard	DCM-200	1½ hp	2010 lbs
ERGO 3660 PRC-6, CDC	123151	2 standard	CDC-6	1½ hp	2130 lbs
ERGO 3660 PRC-9	123121	2 standard	DCM-200A	2 hp	2045 lbs
ERGO 3660 PRC-9, CDC	123152	2 standard	CDC-9	2 hp	2165 lbs
ERGO FaStrip® 3660 PRC-9	123921	2 standard	DCM-200A	2 hp	2120 lbs
ERGO FaStrip® 3660 PRC-9, CDC	123951	2 standard	CDC-9	2 hp	2240 lbs
ERGO 3696 TWIN PRC-4,	124101	2 standard	(2) DCM-80A	(2) 1 hp	2975 lbs
ERGO 3696 TWIN PRC-6	124121	2 standard	(2) DCM-200	(2) 1½ hp	2900 lbs
ERGO 3696 TWIN, PRC-6, CDC	124151	2 standard	(2) CDC-6	(2) 1½ hp	3500 lbs
ERGO 4848 PRC-6	122101	2 standard	DCM-200	1½ hp	1735 lbs
ERGO 4848 PRC-6, CDC	122151	2 standard	CDC-6	1½ hp	2035 lbs
ERGO 4848 PRC-9	122121	2 standard	DCM-200A	2 hp	1775 lbs
ERGO 4848 PRC-9, CDC	122152	2 standard	CDC-9	2 hp	2075 lbs
ERGO FaStrip® 4848 PRC-9	122921	2 standard	DCM-200A	2 hp	1800 lbs
ERGO FaStrip® 4848 PRC-9, CDC	122951	2 standard	CDC-9	2 hp	2050 lbs
ERGO 6060 PRC-9	125121	2 standard	DCM-200A	2 hp	2049 lbs
ERGO 6060 PRC-9, CDC	125152	2 standard	CDC-9	2 hp	2168 lbs
ERGO FaStrip® 6060 PRC-9	125921	2 standard	DCM-200A	2 hp	2074 lbs
ERGO FaStrip® 6060 PRC-9, CDC	125951	2 standard	CDC-9	2 hp	2193 lbs

Ergo-Blast Cabinets (Suction Systems)

MODEL DESCRIPTION	PART NUMBER	NUMBER OF DOORS	DUST COLLECTION	BLOWER MOTOR	SHIPPING WEIGHT
ERGO 2636 SRC-4	120001	1 standard	DCM-80A	1 hp	800 lbs
ERGO 3648 SRC-4	121001	2 standard	DCM-80A	1 hp	920 lbs
ERGO 3648 SRC-6	121021	2 standard	DCM-200	1½ hp	1365 lbs
ERGO 3648 SRC-6, CDC	121051	2 standard	CDC-6	1½ hp	1665 lbs
ERGO 3660 SRC-6	123001	2 standard	DCM-200	1½ hp	1797 lbs
ERGO 3660 SRC-6, CDC	123051	2 standard	CDC-6	1½ hp	1917 lbs
ERGO 3660 SRC-9	123021	2 standard	DCM-200A	2 hp	1832 lbs
ERGO 3660 SRC-9, CDC	123052	2 standard	CDC-9	2 hp	1952 lbs
ERGO TWIN 3696 SRC-4,	124001	2 standard	(2) DCM-80A	(2) 1 hp	1840 lbs
ERGO TWIN 3696 SRC-6	124021	2 standard	(2) DCM-200	(2) 1½ hp	2850 lbs
ERGO TWIN 3696 SRC-6, CDC	124051	2 standard	(2) CDC-6	(2) 1½ hp	3450 lbs
ERGO 4848 SRC-6	122001	2 standard	DCM-200	1½ hp	1525 lbs
ERGO 4848 SRC-6, CDC	122051	2 standard	CDC-6	1½ hp	1825 lbs
ERGO 4848 SRC-9	122021	2 standard	DCM-200A	2 hp	1566 lbs
ERGO 4848 SRC-9, CDC	122052	2 standard	CDC-9	2 hp	1860 lbs
ERGO 6060 SRC-9	125021	2 standard	DCM-200A	2 hp	1836 lbs
ERGO 6060 SRC-9, CDC	125052	2 standard	CDC-9	2 hp	1956 lbs

Pro-Finish® Cabinet Models

FaStrip® Cabinets

MODEL DESCRIPTION	PART NUMBER	NUMBER OF DOORS	DUST COLLECTION	BLOWER MOTOR	SHIPPING WEIGHT
FaStrip® 2636 PRC-6	102130	1 standard	DCM-200	1½ hp	1380 lbs
FaStrip® 2636 PRC-6, CDC	102159	1 standard	CDC-6	1½ hp	1495 lbs
FaStrip® 2636 PR-6	140959	1 standard	—	—	660 lbs
ERGO FaStrip® 3648 PRC-6	121921	2 standard	DCM-200	1½ hp	1600 lbs
ERGO FaStrip® 3648 PRC-6, CDC	121951	2 standard	CDC-6	1½ hp	1900 lbs
FaStrip® 3648 PR-6	140950	2 standard	—	—	775 lbs
FaStrip® 3648 PRC-6	103129	2 standard	DCM-200	1½ hp	1500 lbs
FaStrip® 3648 PRC-6, CDC	103159	2 standard	CDC-6	1½ hp	1800 lbs
ERGO FaStrip® 3660 PRC-9	123921	2 standard	DCM-200A	2 hp	2075 lbs
ERGO FaStrip® 3660 PRC-9, CDC	123951	2 standard	CDC-9	2 hp	2195 lbs
FaStrip® 3660 PR-9	126951	2 standard	—	—	1245 lbs
FaStrip® 3660 PRC-9	126129	2 standard	DCM-200A	2 hp	1975 lbs
FaStrip® 3660 PRC-9, CDC	126159	2 standard	CDC-9	2 hp	2095 lbs
FaStrip® 3674 PRC-9	128129	2 standard	DCM-200A	2 hp	1970 lbs
FaStrip® 3674 PRC-9, CDC	128159	2 standard	CDC-9	2 hp	2290 lbs
ERGO FaStrip® 4848 PRC-9	122921	2 standard	DCM-200A	2 hp	1800 lbs
ERGO FaStrip® 4848 PRC-9, CDC	122951	2 standard	CDC-9	2 hp	2050 lbs
FaStrip® 4848 PR-9	140951	2 standard	—	—	965 lbs
FaStrip® 4848 PRC-9	104129	2 standard	DCM-200	1½ hp	1696 lbs
FaStrip® 4848 PRC-9, CDC	104159	2 standard	CDC-9	1½ hp	1816 lbs
ERGO FaStrip® 6060 PRC-9	125921	2 standard	DCM-200A	2 hp	2074 lbs
ERGO FaStrip® 6060 PRC-9, CDC	125951	2 standard	CDC-9	2 hp	2193 lbs
FaStrip® 6060 PR-9	140952	2 standard	—	—	1249 lbs
FaStrip® 6060 PRC-9	105129	2 standard	DCM-200A	2 hp	1975 lbs
FaStrip® 6060 PRC-9, CDC	105159	2 standard	CDC-9	2 hp	2094 lbs
FaStrip® 7272 PRC-9	127901	1 standard	DCM-200A	2 hp	3000 lbs
FaStrip® 7272 PRC-12	127923	1 standard	DCM-200B	5 hp	3100 lbs

SafeStrip™ Fine Media Cabinets (Supplied with SafeStrip™ Pot)

MODEL DESCRIPTION	PART NUMBER	NUMBER OF DOORS	DUST COLLECTION	BLOWER MOTOR	SHIPPING WEIGHT
SafeStrip™ 2636	102032	1 standard	DCM-200	1½ hp	1870 lbs
SafeStrip™ 2636 CDC	102033	1 standard	CDC-6	1½ hp	1990 lbs
SafeStrip™ 3648	103032	2 standard	DCM-200	1½ hp	1985 lbs
SafeStrip™ 3648 CDC	103033	2 standard	CDC-6	1½ hp	2105 lbs
SafeStrip™ 4848	104032	2 standard	DCM-200	1½ hp	2070 lbs
SafeStrip™ 4848 CDC	104033	2 standard	CDC-6	1½ hp	2190 lbs
SafeStrip™ 6060	105032	2 standard	DCM-200A	2 hp	2425 lbs
SafeStrip™ 6060 CDC	105033	2 standard	CDC-9	2 hp	2545 lbs

Single-Pass Cabinets (Supplied with Cabinet Pot)

MODEL DESCRIPTION	PART NUMBER	NUMBER OF DOORS	DUST COLLECTION	BLOWER MOTOR	SHIPPING WEIGHT
2636 PRC-6	102031	1 standard	DCM-200	1½ hp	1800 lbs
2636 PRC-6, CDC	102034	1 standard	CDC-6	1½ hp	1920 lbs
3648 PRC-6	103031	2 standard	DCM-200	1½ hp	1915 lbs
3648 PRC-6, CDC	103034	2 standard	CDC-6	1½ hp	2035 lbs
4848 PRC-6	104031	2 standard	DCM-200	1½ hp	1758 lbs
4848 PRC-6, CDC	104034	2 standard	CDC-6	1½ hp	1878 lbs
6060 PRC-9	105031	2 standard	DCM-200A	2 hp	2071 lbs
6060 PRC-9 CDC	105034	2 standard	CDC-9	2 hp	2191 lbs



Dust Collector Models

Dust Collectors

MODEL DESCRIPTION	PART NUMBER	COLLECTOR TYPE	FILTRATION AREA	BLOWER MOTOR	SHIPPING WEIGHT
DCM-80A	112000	Bag house	80 ft ²	1 hp	300 lbs
DCR-80	112100	Bag house	80 ft ²	—	250 lbs
DCM-200	113000	Bag house	200 ft ²	1½ hp	730 lbs
DCM-200A	113001	Bag house	200 ft ²	2 hp	730 lbs
DCM-200B	113002	Bag house	200 ft ²	5 hp	850 lbs
CDC-6	113007	Cartridge	452 ft ²	1½ hp	850 lbs
CDC-9	113011	Cartridge	452 ft ²	2 hp	850 lbs
CDC-12	113013	Cartridge	452 ft ²	5 hp	925 lbs
SEM-2, 1 hp	113033	Cartridge	206 ft ²	1 hp	575 lbs
SEM-2, 1½ hp	113032	Cartridge	206 ft ²	1½ hp	575 lbs





Pro-Finish® Options

2636 Cabinets including Ergo-Blast & FaStrip® (400 and 600 CFM)

	FACTORY INSTALLED	CUSTOMER INSTALLED	SEE PAGE
Three-Phase Electrical Options (400 CFM)			
Single Source:			
208 Volt, 60 Hertz	139042	139117	A36
230 Volt, 60 Hertz	139043	139118	A36
460 Volt, 60 Hertz	139044	139119	A36
575 Volt, 60 Hertz	139045	139120	A36
380 Volt, 50 Hertz	139046	139121	A36
Three-Phase Electrical Options (600 CFM)			
Single Source:			
208 Volt, 60 Hertz	139047	139122	A36
230 Volt, 60 Hertz	139048	139123	A36
460 Volt, 60 Hertz	139049	139124	A36
575 Volt, 60 Hertz	139050	139125	A36
380 Volt, 50 Hertz	139051	139126	A36
Cabinet Extended-Wear Options			
Black curtain for cone	510751	510831	A59
Black curtain for cone, ERGO	510751-ERGO	510831-ERGO	A59
Black curtains for front wall	140642	140643	A59
Black curtains for front wall, ERGO	140642-ERGO	140643-ERGO	A59
Black curtains for interior sides and back wall	510791	510871	A59
Black curtains for interior sides and back wall, ERGO	510791-ERGO	510871-ERGO	A59
Conveying hose, heavy duty, 4" x 9'	140338	140354	A67
White curtain for cone	140550	140558	A59
White curtain for cone, ERGO	140550-ERGO	140558-ERGO	A59
White curtains for front wall	140767	140969	A59
White curtains for front wall, ERGO	140767-ERGO	140969-ERGO	A59
White curtains for interior sides and back wall	140554	140562	A59
White curtains for interior sides and back wall, ERGO	140554-ERGO	140562-ERGO	A59
Window protector, plastic	509191	509191	A64
Window protector, mesh screen	509201	509201	A64
Reclaimer Extended-Wear Options (400 CFM)			
Wear plate	514471	514501	A67
Reclaimer Extended-Wear Options (600 CFM)			
Ultrawear lining	526183	N/A	A67
Wear plate	514481	514511	A67
Cabinet Options			
2'n*1 door basket, coated	140404	140405	A58
2'n*1 door basket, standard (uncoated)	140342	140406	A58
Antistatic strap	510411	510411	A58
Armrest assembly (included with Ergo-Blast)	140595	140595	A58

continued on next page



Options: Pro-Finish® Systems

2636 Cabinets including Ergo-Blast & FaStrip®—continued

	FACTORY INSTALLED	CUSTOMER INSTALLED	SEE PAGE
Door locking clamp, right side without timer	140624	140626	A58
Door locking clamp, right side with timer	140628	140630	A58
Glove hole plugs	140623	140622	A58
HEPA filter, cabinet inlet	Call factory	Call factory	A58
Left-side door	140345	140603	—
Magnetic separator (included with FaStrip®)	511572	511572	A58
Oscillator assembly (specify horizontal or vertical)	140424	140402	A59
Safety matting (specify length)	509002	509002	A60
Sound attenuator (included with Ergo-Blast)	140597	140597	—
System security key-lock	140864	140864	A60
Timer package, electronic	140536	140535	A60
Timer package, mechanical	140420	140421	A60
Turntable, manual, 18" rolling, includes inside/outside tracks	140321	140321	A60
Turntable, manual, 18" stationary	140422	140422	A60
Turntable, manual, 18" stationary, low profile	140574	140574	A60
Turntable, manual, 24" stationary, low profile	140502	140502	A60
Vertical door	140491	140491	A63
Vibrating reclaimer screen assembly (included with FaStrip®)	140335	140419	A64

Pressure Cabinet Options

Blast hose, ½", top entry	140878	140879	A49
Blast hose, ¾", top entry, with ¼" Di-Carb™ nozzle	140635	140634	A68
Boron restrictor for MG-78 valve	290184	290184	A50
Cone, 60 degree, for pressure vessel	505002	140060	A68
Constant pressure control assembly	140523	Call factory	A68
Door sill package (included with Ergo-Blast)	140725	761551	A69
Fine tuning package with choke	140509	140510	A69
Media regulator, aerated	140374	140360	A70
Media sensor, low level	140381	Call factory	A70
MG-78 CR valve (included with FaStrip®)	290234	290232	A71
Nozzle, ⅜" boron	502032	502032	A49
Nozzle, ⅜" Di-Carb™	501282	501282	A49
Nozzle holder, fixed	140401	140401	A71
Nozzles, second nozzle upgrade	140605	140604	A72
Pressure vessel, 3.5 cubic-foot assembly	140609	140607	A74
Sight glasses for 1.5 cubic-foot pressure vessel (two required)	545471	545471	A72
Sight glasses for 3.5 cubic-foot pressure vessel (two required)	545493	545493	A72
Sure-Flo® valve, automatic (included with FaStrip®)	290188	290188	A73

Suction Cabinet Options

Gun holder, fixed	140400	140400	A75
Gun package, four gun upgrade (adds three guns)	140349	140353	A75
Gun package, three gun upgrade (adds two guns)	140348	140352	A75
Gun package, two gun upgrade (adds one gun)	140347	140351	A75
KLEEN™ package	140356	140391	A75
Nozzle, ⅜" boron	502081	502081	A57
Nozzle, ⅜" Di-Carb™	501341	501341	A57



Options: Pro-Finish® Systems

2636 Cabinets including Ergo-Blast & FaStrip®—continued

	FACTORY INSTALLED	CUSTOMER INSTALLED	SEE PAGE
Dust Collector Options for DCM-80A (400 CFM)			
Bag shaker, automatic electric, 115 volts	140340	140390	A65
Bag shaker, automatic pneumatic	140685	140686	A65
HEPA filter	140215-DCM80A	140215-DCM80A	A65
HEPA filter, pressure differential gauge assembly	140221	140221	A65
Leg extension package for 16 gallon drum	140259	140258	A65
Leg extension package for 55 gallon drum	140170/140255	140170/140255	A65
Leg extension stand (only) for 16 gallon drum	140171	140171	A65
Leg extension stand (only) for 55 gallon drum	140170	140170	A65
Lid assembly and drum, 16 gallon	113015	113015	A65
Lid assembly (only) for 55 gallon drum	140155	140155	A65
Manometer, measures pressure differential	140344	140398	A65
Minihelic gauge, measures pressure differential	140841	140842	A65
Sound attenuator/damper, 400 & 600 CFM (85dBA)	140361	140361	A65
Dust Collector Options for SEM-2 (400 & 600 CFM)			
HEPA filter	141090	Call factory	A66
HEPA filter, pressure differential gauge assembly	140221	140221	A66
Photohelic automatic pulse cleaning system	141810	141811	A66
Sound attenuator/damper, 400 & 600 CFM (85dBA)	140966	140966	A66
Sound attenuator, premium, 400 & 600 CFM (80dBA)	141796	141795	A66
Dust Collector Options for DCM-200 (600 CFM)			
Bag shaker, automatic electric, 115 volts	140340	140390	A65
Bag shaker, automatic pneumatic	140683	140684	A65
HEPA filter	140215	140215	A65
HEPA filter, pressure differential gauge assembly	140221	140221	A65
Leg extension package for 16 gallon drum	140182	140181	A65
Leg extension package for 55 gallon drum	140256	140256	A65
Leg extension stand (only) for 16 gallon drum	140185	140185	A65
Leg extension stand (only) for 55 gallon drum	140180	140180	A65
Lid assembly and drum, 16 gallon	113015	113015	A65
Lid assembly (only) for 55 gallon drum	140255	140255	A65
Manometer, measures pressure differential	140344	140398	A65
Minihelic gauge, measures pressure differential	140841	140842	A65
Sound attenuator/damper, 400 & 600 CFM (85dBA)	140361	140361	A65
Dust Collector Options for CDC-6 (600 CFM)			
HEPA filter	140215	140215	A66
HEPA filter, pressure differential gauge assembly	140221	140221	A66
Leg extension package for 55 gallon drum	140257	140257	A66
Leg extension stand (only) for 55 gallon drum	140185	140185	A66
Lid assembly (only) for 55 gallon drum	140155	140155	A66
Photohelic automatic cleaning system	140900	141900	A66
Photohelic automatic cleaning system with leg extension	141901	141902	A66
Sound attenuator/damper, 600 CFM (85dBA)	140361	140361	A66
Higher Volume Ventilation Options			
900 CFM equipment	Call factory	Call factory	—
1200 CFM equipment	Call factory	Call factory	—



Options: Pro-Finish® Systems

2636 SafeStrip™ and Single-Pass Models (600 CFM)

	FACTORY INSTALLED	CUSTOMER INSTALLED	SEE PAGE
Three-Phase Electrical Options (600 CFM)			
Single Source:			
208 Volt, 60 Hertz	139047	139122	A36
230 Volt, 60 Hertz	139048	139123	A36
460 Volt, 60 Hertz	139049	139124	A36
575 Volt, 60 Hertz	139050	139125	A36
380 Volt, 50 Hertz	139051	139126	A36
Cabinet Extended-Wear Options			
Black curtain for cone	510751	510831	A59
Black curtains for front wall	140642	140643	A59
Black curtains for interior sides and back wall	510791	510871	A59
Conveying hose, heavy duty, 6" x 9'	140338	140354	A67
White curtain for cone	140550	140558	A59
White curtains for front wall	140767	140969	A59
White curtains for interior sides and back wall	140554	140562	A59
Window protector, plastic	509191	509191	A64
Window protector, mesh screen	509201	509201	A64
Cabinet Options			
2'n'1 door basket, coated	140404	140405	A58
2'n'1 door basket, standard (uncoated)	140342	140406	A58
Antistatic strap	510411	510411	A58
Armrest assembly	140595	140595	A58
Blast hose, 1/2", top entry	140878	140879	A49
Blast hose, 3/4", top entry, with 1/4" Di-Carb™ nozzle	140635	140634	A66
Boron restrictor for MG-78 valve (not available with SafeStrip™)	290184	290184	A50
Cone, 60 degree, for pressure vessel (not available with SafeStrip™)	505002	140060	A68
Door locking clamp, right side with timer	140628	140630	A58
Door locking clamp, right side without timer	140624	140626	A58
Door sill package	140725	761551	A69
Glove hole plugs	140623	140622	A58
HEPA filter, cabinet inlet	Call factory	Call factory	A58
Media sensor, low level (not available with SafeStrip™)	140361	140361	A70
Left-side door	140345	140603	—
Nozzle, 3/16" boron	502032	502032	A49
Nozzle, 3/16" Di-Carb™	501282	501282	A49
Nozzle holder, fixed	140401	140401	A71
Oscillator assembly (specify horizontal or vertical)	140424	140402	A59
Safety matting (specify length)	509002	509002	A60
Sight glasses for pressure vessel (two required) (not available with SafeStrip™)	545471	545471	A72
Sound attenuator	140597	140597	—
System security key-lock	140864	140864	A60
Timer package, electric	140536	140535	A60
Timer package, mechanical	140420	140421	A60
Turntable, manual, 18" rolling, includes inside/outside tracks	140321	140321	A60
Turntable, manual, 18" stationary	140422	140422	A60
Turntable, manual, 18" stationary, low profile	140574	140574	A60
Turntable, manual, 24" stationary, low profile	140502	140502	A60
Vertical door	140491	140491	A63

continued on next page



Options: Pro-Finish® Systems

2636 SafeStrip™ and Single-Pass Models—continued

	FACTORY INSTALLED	CUSTOMER INSTALLED	SEE PAGE
Dust Collector Options for DCM-200 (600 CFM)			
Bag shaker, automatic electric, 115 volts	140340	140390	A65
Bag shaker, automatic pneumatic	140683	140684	A65
HEPA filter	140215	140215	A65
HEPA filter, pressure differential gauge assembly	140221	140221	A65
Leg extension package for 16 gallon drum	140182	140181	A65
Leg extension package for 55 gallon drum	140256	140256	A65
Leg extension stand (only) for 16 gallon drum	140185	140185	A65
Leg extension stand (only) for 55 gallon drum	140180	140180	A65
Lid assembly and drum, 16 gallon	113015	113015	A65
Lid assembly (only) for 55 gallon drum	140255	140255	A65
Manometer, measures pressure differential	140344	140398	A65
Minihelic gauge, measures pressure differential	140841	140842	A65
Sound attenuator/damper, 400 & 600 CFM (85dBA)	140361	140361	A65
Dust Collector Options for CDC-6 (600 CFM)			
HEPA filter	140215	140215	A66
HEPA filter, pressure differential gauge assembly	140221	140221	A66
Leg extension package for 55 gallon drum	140257	140257	A66
Leg extension stand (only) for 55 gallon drum	140185	140185	A66
Lid assembly (only) for 55 gallon drum	140155	140155	A66
Photohelic automatic cleaning system	140900	141900	A66
Photohelic automatic cleaning system with leg extension	141901	141902	A66
Sound attenuator/damper, 600 CFM (85dBA)	140361	140361	A66
Higher Volume Ventilation Options			
900 CFM equipment	Call factory	Call factory	—
1200 CFM equipment	Call factory	Call factory	—





Options: Pro-Finish® Systems

3648 Cabinets including Ergo-Blast and FaStrip® (400, 600 and 900 CFM)

	FACTORY INSTALLED	CUSTOMER INSTALLED	SEE PAGE
Three-Phase Electrical Options (400 CFM)			
Single Source:			
208 Volt, 60 Hertz	139042	139117	A36
230 Volt, 60 Hertz	139043	139118	A36
460 Volt, 60 Hertz	139044	139119	A36
575 Volt, 60 Hertz	139045	139120	A36
380 Volt, 50 Hertz	139046	139121	A36
Three-Phase Electrical Options (600 CFM)			
Single Source:			
208 Volt, 60 Hertz	139047	139122	A36
230 Volt, 60 Hertz	139048	139123	A36
460 Volt, 60 Hertz	139049	139124	A36
575 Volt, 60 Hertz	139050	139125	A36
380 Volt, 50 Hertz	139051	139126	A36
Cabinet Extended-Wear Options			
Black curtain for cone	510761	510841	A59
Black curtain for cone, ERGO	510761-ERGO	510841-ERGO	A59
Black curtains for front wall	140640	140641	A59
Black curtains for front wall, ERGO	140640-ERGO	14064-ERGO	A59
Black curtains for interior sides and back wall	510801	510881	A59
Black curtains for interior sides and back wall, ERGO	510801-ERGO	510881-ERGO	A59
Conveying hose, heavy duty, 4" x 9' (600 CFM)	140338	140354	A67
Conveying hose, heavy duty, 6" x 12' (900 CFM)	140339	140355	A67
White curtain for cone	140551	140559	A59
White curtain for cone, ERGO	140551-ERGO	140559-ERGO	A59
White curtains for front wall	140577	140973	A59
White curtains for front wall, ERGO	140577-ERGO	140973-ERGO	A59
White curtains for interior sides and back wall	140555	140563	A59
White curtains for interior sides and back wall, ERGO	140555-ERGO	140563-ERGO	A59
Window protector, plastic	509191	509191	A64
Window protector, mesh screen	509201	509201	A64
Reclaimer Extended-Wear Options (400 CFM)			
Wear plate	514471	514501	A67
Reclaimer Extended-Wear Options (600 CFM)			
Ultrawear lining	526183	N/A	A67
Wear plate	514481	514511	A67
Reclaimer Extended-Wear Options (900 CFM)			
Ultrawear lining	526193	N/A	A67
Wear plate	514491	514521	A67
Cabinet Options			
2'n'1 door basket, coated	140404	140405	A58
2'n'1 door basket, standard (uncoated)	140342	140406	A58
Antistatic strap	510411	510411	A58
Armrest assembly (included with Ergo-Blast)	140596	140596	A58
Door locking clamp, right side with timer	140628	140630	A58
Door locking clamp, right side without timer	140624	140626	A58
Door locking clamp, two doors with timer	140629	140631	A58
Door locking clamp, two doors without timer	140625	140627	A58
Glove hole plugs	140623	140622	A58
HEPA filter, cabinet inlet	140190	140190	A58
Magnetic separator (included with FaStrip®)	511572	511572	A58
Oscillator assembly (specify horizontal or vertical)	140424	140402	A59
Safety matting (specify length)	509002	509002	A60

continued on next page



Options: Pro-Finish® Systems

3648 Cabinets including Ergo-Blast and FaStrip® (continued)

	FACTORY INSTALLED	CUSTOMER INSTALLED	SEE PAGE
Sound attenuator (included with Ergo-Blast)	140597	140597	A60
System security key-lock	140864	140864	A60
Timer package, electric	140536	140535	A60
Timer package, mechanical	140420	140421	A60
Turntable, manual, 18" stationary	140422	140422	A60
Turntable, manual, 18" stationary, low profile	140574	140574	A60
Turntable, manual, 24" rolling, includes inside/outside tracks	140322	140322	A60
Turntable, manual, 24" stationary, low profile	140502	140502	A60
Turntable, powered, 24" rolling, includes inside/outside tracks (Consult Factory!)	140364	140364	A60
Turntable, powered, 24" stationary, low profile (not available with Ergo-Blast)	140504	140504	A60
Vertical door	140490	140490	A63
Vibrating reclamer screen assembly (included with FaStrip®)	140335	140419	A64

Pressure Cabinet Options

Blast hose, ½", top entry	140878	140879	A48
Blast hose, ¾", top entry, with ¼" Di-Carb™ nozzle	140635	140634	A68
Boron restrictor for MG-78 valve	290184	290184	A50
Cone, 60 degree, for pressure vessel	505002	140060	A68
Constant pressure control assembly	140523	Call Factory	A68
Door sill package for one door (two included with Ergo-Blast)	140726	761561	A69
Fine tuning package with choke	140509	140510	A69
Media regulator, aerated	140374	140360	A70
Media sensor, low level	140381	Call Factory	A70
MG-78 CR valve (included with FaStrip®)	290234	290232	A71
Nozzle, ⅜" boron	502032	502032	A49
Nozzle, ⅜" Di-Carb™	501282	501282	A49
Nozzle holder, fixed	140401	140401	A71
Nozzles, second nozzle upgrade	140605	140604	A72
Pressure vessel, 3.5 cubic-foot assembly	140609	140607	A74
Sight glasses for 1.5 cubic-foot pressure vessel (two required)	545471	545471	A72
Sight glasses for 3.5 cubic-foot pressure vessel (two required)	545493	545493	A72
Sure-Flo® valve, automatic (included with FaStrip®)	290188	290188	A73

Suction Cabinet Options

Gun holder, fixed	140400	140400	A75
Gun package, four gun upgrade (adds three guns)	140349	140353	A75
Gun package, three gun upgrade (adds two guns)	140348	140352	A75
Gun package, two gun upgrade (adds one gun)	140347	140351	A75
KLEEN™ package	140357	140392	A75
Nozzle, ⅜" boron	502081	502081	A57
Nozzle, ⅜" Di-Carb™	501341	501341	A57

Dust Collector Options for DCM-80A (400 CFM)

Bag shaker, automatic electric, 115 volts	140340	140390	A65
Bag shaker, automatic pneumatic	140685	140686	A65
HEPA filter	140215-DCM80A	140215-DCM80A	A65
HEPA filter, pressure differential gauge assembly	140221	140221	A65
Leg extension package for 16 gallon drum	140259	140258	A65
Leg extension package for 55 gallon drum	140170/140255	140170/140255	A65
Leg extension stand (only) for 16 gallon drum	140171	140171	A65
Leg extension stand (only) for 55 gallon drum	140170	140170	A65
Lid assembly and drum, 16 gallon	113015	113015	A65
Lid assembly (only) for 55 gallon drum	140155	140155	A65
Manometer, measures pressure differential	140344	140398	A65
Minihelic gauge, measures pressure differential	140841	140842	A65
Sound attenuator/damper, 400 & 600 CFM (85dBA)	140361	140361	A65

continued on next page



Options: Pro-Finish® Systems

3648 Cabinets including Ergo-Blast and FaStrip® (continued)

	FACTORY INSTALLED	CUSTOMER INSTALLED	SEE PAGE
Dust Collector Options for SEM-2 (400 & 600 CFM)			
HEPA filter	141090	Call factory	A66
HEPA filter, pressure differential gauge assembly	140221	140221	A66
Photohelic automatic pulse cleaning system	141810	141811	A66
Sound attenuator/damper, 400 & 600 CFM (85dBA)	140966	140966	A66
Sound attenuator, premium, 400 & 600 CFM (80dBA)	141796	141795	A66

Dust Collector Options for DCM-200 (600 CFM)			
Bag shaker, automatic electric, 115 volts	140340	140390	A65
Bag shaker, automatic pneumatic	140683	140684	A65
HEPA filter	140215	140215	A65
HEPA filter, pressure differential gauge assembly	140221	140221	A65
Leg extension package for 16 gallon drum	140182	140181	A65
Leg extension package for 55 gallon drum	140256	140256	A65
Leg extension stand (only) for 16 gallon drum	140185	140185	A65
Leg extension stand (only) for 55 gallon drum	140180	140180	A65
Lid assembly and drum, 16 gallon	113015	113015	A65
Lid assembly (only) for 55 gallon drum	140255	140255	A65
Manometer, measures pressure differential	140344	140398	A65
Minihelic gauge, measures pressure differential	140841	140842	A65
Sound attenuator/damper, 400 & 600 CFM (85dBA)	140361	140361	A65

Dust Collector Options for CDC-6 (600 CFM)			
HEPA filter	140215	140215	A66
HEPA filter, pressure differential gauge assembly	140221	140221	A66
Leg extension package for 55 gallon drum	140257	140257	A66
Leg extension stand (only) for 55 gallon drum	140185	140185	A66
Lid assembly (only) for 55 gallon drum	140155	140155	A66
Photohelic automatic cleaning system	140900	141900	A66
Photohelic automatic cleaning system with leg extension	141901	141902	A66
Sound attenuator/damper, 600 CFM (85dBA)	140361	140361	A66

Dust Collector Options for DCM-200A(900 CFM)			
Bag shaker, automatic electric, 115 volts	140340	140390	A65
Bag shaker, automatic pneumatic	140683	140684	A65
HEPA filter	140215	140215	A65
HEPA filter, pressure differential gauge assembly	140221	140221	A65
Leg extension package for 16 gallon drum	140182	140181	A65
Leg extension package for 55 gallon drum	140256	140256	A65
Leg extension stand (only) for 16 gallon drum	140185	140185	A65
Leg extension stand (only) for 55 gallon drum	140180	140180	A65
Lid assembly and drum, 16 gallon	113015	113015	A65
Lid assembly (only) for 55 gallon drum	140255	140255	A65
Manometer, measures pressure differential	140344	140398	A65
Minihelic gauge, measures pressure differential	140841	140842	A65
Sound attenuator/damper, 900 CFM (85dBA)	140769	140769	A65

Dust Collector Options for CDC-9 (900 CFM)			
HEPA filter	140215	140215	A66
HEPA filter, pressure differential gauge assembly	140221	140221	A66
Leg extension package for 55 gallon drum	140257	140257	A66
Leg extension stand (only) for 55 gallon drum	140185	140185	A66
Lid assembly (only) for 55 gallon drum	140155	140155	A66
Photohelic automatic cleaning system	140900	141900	A66
Photohelic automatic cleaning system with leg extension	141901	141902	A66
Sound attenuator/damper, 900 CFM (85dBA)	140769	140769	A66

Higher Volume Ventilation Options			
1200 CFM equipment	Call factory	Call factory	—





3648 SafeStrip™ and Single-Pass Models (600 CFM)

	FACTORY INSTALLED	CUSTOMER INSTALLED	SEE PAGE
Three-Phase Electrical Options (600 CFM)			
Single Source:			
208 Volt, 60 Hertz	139047	139122	A36
230 Volt, 60 Hertz	139048	139123	A36
460 Volt, 60 Hertz	139049	139124	A36
575 Volt, 60 Hertz	139050	139125	A36
380 Volt, 50 Hertz	139051	139126	A36
Cabinet Extended-Wear Options			
Black curtain for cone	510801	510841	A59
Black curtains for front wall	140640	140641	A59
Black curtains for interior sides and back wall	510791	510871	A59
Conveying hose, heavy duty, 6" x 9'	140338	140354	A67
White curtain for cone	140551	140559	A59
White curtains for front wall	140577	140973	A59
White curtains for interior sides and back wall	140555	140563	A59
Window protector, plastic	509191	509191	A64
Window protector, screen	509201	509201	A64
Cabinet Options			
2'n'1 door basket, coated	140404	140405	A58
2'n'1 door basket, standard (uncoated)	140342	140406	A58
Antistatic strap	510411	510411	A58
Armrest assembly	140596	140596	A58
Blast hose, 1/2", top entry	140878	140879	A49
Blast hose, 3/4", top entry, with 1/4" Di-Carb™ nozzle	140635	140634	A66
Boron restrictor for MG-78 valve (not available with SafeStrip™)	290184	290184	A50
Cone, 60 degree, for pressure vessel (not available with SafeStrip™)	505002	140060	A68
Door locking clamp, right side with timer	140628	140630	A58
Door locking clamp, right side without timer	140624	140626	A58
Door locking clamp, two doors with timer	140629	140631	A58
Door locking clamp, two doors without timer	140625	140627	A58
Door sill package for one door	140726	761561	A69
Glove hole plugs	140623	140622	A58
Media sensor, low level (not available with SafeStrip™)	140361	140361	A70
HEPA filter, cabinet inlet	140190	140190	A58
Nozzle, 3/16" boron	502032	502032	A49
Nozzle, 3/16" Di-Carb™	501282	501282	A49
Nozzle holder, fixed	140401	140401	A71
Oscillator assembly (specify horizontal or vertical)	140424	140402	A59
Safety matting (specify length)	509002	509002	A60
Sight glasses for 1.5 cubic-foot pressure vessel (two required)	545471	545471	A72
Sight glasses for 3.5 cubic-foot pressure vessel (two required)	545493	545493	A72
Sound attenuator	140597	140597	—
System security key-lock	140864	140864	A60
Timer package, electric	140536	140535	A60
Timer package, mechanical	140420	140421	A60
Turntable, manual, 18" stationary	140422	140422	A60
Turntable, manual, 18" stationary, low profile	140574	140574	A60
Turntable, manual, 24" rolling, includes inside/outside tracks	140322	140322	A60

continued on next page



Options: Pro-Finish® Systems

3648 SafeStrip™ and Single-Pass Models—continued

	FACTORY INSTALLED	CUSTOMER INSTALLED	SEE PAGE
Turntable, manual, 24" stationary, low profile	140502	140502	A60
Turntable, powered, 24" rolling, includes inside/outside tracks (Consult Factory!)	140364	140364	A60
Turntable, powered, 24" stationary, low profile	140504	140504	A60
Vertical door	140490	140490	A63

Dust Collector Options for DCM-200 (600 CFM)

Bag shaker, automatic electric, 115 volts	140340	140390	A65
Bag shaker, automatic pneumatic	140683	140684	A65
HEPA filter	140215	140215	A65
HEPA filter, pressure differential gauge assembly	140221	140221	A65
Leg extension package for 16 gallon drum	140182	140181	A65
Leg extension package for 55 gallon drum	140256	140256	A65
Leg extension stand (only) for 16 gallon drum	140185	140185	A65
Leg extension stand (only) for 55 gallon drum	140180	140180	A65
Lid assembly and drum, 16 gallon	113015	113015	A65
Lid assembly (only) for 55 gallon drum	140255	140255	A65
Manometer, measures pressure differential	140344	140398	A65
Minihelic gauge, measures pressure differential	140841	140842	A65
Sound attenuator/damper, 400 & 600 CFM (85dBA)	140361	140361	A65

Dust Collector Options for CDC-6 (600 CFM)

HEPA filter	140215	140215	A66
HEPA filter, pressure differential gauge assembly	140221	140221	A66
Leg extension package for 55 gallon drum	140257	140257	A66
Leg extension stand (only) for 55 gallon drum	140185	140185	A66
Lid assembly (only) for 55 gallon drum	140155	140155	A66
Photohelic automatic cleaning system	140900	141900	A66
Photohelic automatic cleaning system with leg extension	141901	141902	A66
Sound attenuator/damper, 600 CFM (85dBA)	140361	140361	A66

Higher Volume Ventilation Options

900 CFM equipment	Call factory	Call factory	—
1200 CFM equipment	Call factory	Call factory	—





3660 Cabinets including Ergo-Blast and FaStrip® (600 and 900 CFM)

	FACTORY INSTALLED	CUSTOMER INSTALLED	SEE PAGE
Three-Phase Electrical Options (600 CFM)			
Single Source:			
208 Volt, 60 Hertz	139047	139122	A36
230 Volt, 60 Hertz	139048	139123	A36
460 Volt, 60 Hertz	139049	139124	A36
575 Volt, 60 Hertz	139050	139125	A36
380 Volt, 50 Hertz	139051	139126	A36
Three-Phase Electrical Options (900 CFM)			
Single Source:			
208 Volt, 60 Hertz	139052	139127	A36
230 Volt, 60 Hertz	139053	139128	A36
460 Volt, 60 Hertz	139054	139129	A36
575 Volt, 60 Hertz	139055	139130	A36
380 Volt, 50 Hertz	139056	139131	A36
Cabinet Extended-Wear Options			
Black curtain for cone	510872	140832	A59
Black curtain for cone, ERGO	510872-ERGO	140832-ERGO	A59
Black curtains for front wall	140827	140833	A59
Black curtains for front wall, ERGO	140827-ERGO	140833-ERGO	A59
Black curtains for interior sides and back wall	140828	140834	A59
Black curtains for interior sides and back wall, ERGO	140828-ERGO	140834-ERGO	A59
Conveying hose, heavy duty, 4" x 9' (600 CFM)	140338	140354	A67
Conveying hose, heavy duty, 6" x 12" (900 CFM)	140339	140355	A67
White curtain for cone	140829	140835	A59
White curtain for cone, ERGO	140829-ERGO	140835-ERGO	A59
White curtains for front wall	140830	140836	A59
White curtains for front wall, ERGO	140830-ERGO	140836-ERGO	A59
White curtains for interior sides and back wall	140831	140837	A59
White curtains for interior sides and back wall, ERGO	140831-ERGO	140837-ERGO	A59
Window protector, plastic	509191	509191	A64
Window protector, mesh screen	509201	509201	A64
Reclaimer Extended-Wear Options (600 CFM)			
Ultrawear lining	526183	N/A	A67
Wear plate	514481	514511	A67
Reclaimer Extended-Wear Options (900 CFM)			
Ultrawear lining	526193	N/A	A67
Wear plate	514491	514521	A67
Cabinet Options			
2'n'1 door basket, coated	140404	140405	A58
2'n'1 door basket, standard (uncoated)	140342	140406	A58
Antistatic strap	510411	510411	A58
Armrest assembly (included with Ergo-Blast)	140596	140596	A58
Door locking clamp, right side with timer	140628	140630	A58
Door locking clamp, right side without timer	140624	140626	A58

continued on next page



Options: Pro-Finish® Systems

3660 Cabinets including Ergo-Blast and FaStrip®—continued

	FACTORY INSTALLED	CUSTOMER INSTALLED	SEE PAGE
Door locking clamp, two doors with timer	140629	140631	A58
Door locking clamp, two doors without timer	140625	140627	A58
Glove hole plugs	140623	140622	A58
HEPA filter, cabinet inlet	140190	140190	A58
Magnetic separator (included with FaStrip®)	511572	511572	A58
Oscillator assembly (specify horizontal or vertical)	140424	140402	A59
Safety matting (specify length)	509002	509002	A60
Sound attenuator (included with Ergo-Blast)	140597	140597	—
System security key-lock	140864	140864	A60
Timer package, electric	140536	140535	A60
Timer package, mechanical	140420	140421	A60
Turntable, manual, 18" stationary	140422	140422	A60
Turntable, manual, 18" stationary, low profile	140574	140574	A60
Turntable, manual, 24" rolling, includes inside/outside tracks	140324	140324	A60
Turntable, manual, 24" stationary, low profile	140502	140502	A60
Turntable, powered, 24" rolling, includes inside/outside tracks (Consult Factory!)	140375	140375	A60
Turntable, powered, 24" stationary, low profile (not available with Ergo-Blast)	140504	140504	A60
Vertical door	140490	140490	A63
Vibrating reclaiming screen assembly (included with FaStrip®)	140335	140419	A64

Pressure Cabinet Options

Blast hose, ½", top entry	140878	140879	A49
Blast hose, ¾", top entry, with ¼" Di-Carb™ nozzle	140635	140634	A68
Boron restrictor for MG-78 valve	290184	290184	A50
Cone, 60 degree, for pressure vessel	505002	140060	A68
Constant pressure control assembly	140523	Call Factory	A68
Door sill package for one door (two included with Ergo-Blast)	140726	761561	A69
Fine tuning package with choke	140509	140510	A69
Media regulator, aerated	140374	140360	A70
Media sensor, low level	140381	Call Factory	A70
MG-78 CR valve (included with FaStrip®)	290234	290232	A71
Nozzle, ¼" boron	502032	502032	A49
Nozzle, ¼" Di-Carb™	501282	501282	A49
Nozzle holder, fixed	140401	140401	A71
Nozzles, second nozzle upgrade	140605	140604	A72
Pressure vessel, 3.5 cubic-foot assembly, 600 CFM	140609	140607	A74
Pressure vessel, 3.5 cubic-foot assembly, 900 CFM	140610	140608	A74
Sight glasses for 1.5 cubic-foot pressure vessel (two required)	545471	545471	A72
Sight glasses for 3.5 cubic-foot pressure vessel (two required)	545493	545493	A72
Sure-Flo® valve, automatic (included with FaStrip®)	290188	290188	A73

Suction Cabinet Options

Gun holder, fixed	140400	140400	A75
Gun package, four gun upgrade (adds three guns)	140349	140353	A75
Gun package, three gun upgrade (adds two guns)	140348	140352	A75
Gun package, two gun upgrade (adds one gun)	140347	140351	A75
KLEEN™ package	140357	140392	A75
Nozzle, ¼" boron	502081	502081	A57
Nozzle, ¼" Di-Carb™	501341	501341	A57

continued on next page



Options: Pro-Finish® Systems

3660 Cabinets including Ergo-Blast and FaStrip®—continued

	FACTORY INSTALLED	CUSTOMER INSTALLED	SEE PAGE
Dust Collector Options for DCM-200 (600 CFM)			
Bag shaker, automatic electric, 115 volts	140340	140390	A65
Bag shaker, automatic pneumatic	140683	140684	A65
HEPA filter	140215	140215	A65
HEPA filter, pressure differential gauge assembly	140221	140221	A65
Leg extension package for 16 gallon drum	140182	140181	A65
Leg extension package for 55 gallon drum	140256	140256	A65
Leg extension stand (only) for 16 gallon drum	140185	140185	A65
Leg extension stand (only) for 55 gallon drum	140180	140180	A65
Lid assembly and drum, 16 gallon	113015	113015	A65
Lid assembly (only) for 55 gallon drum	140255	140255	A65
Manometer, measures pressure differential	140344	140398	A65
Minihelic gauge, measures pressure differential	140841	140842	A65
Sound attenuator/damper, 400 & 600 CFM (85dBA)	140361	140361	A65

Dust Collector Options for CDC-6 (600 CFM)			
HEPA filter	140215	140215	A66
HEPA filter, pressure differential gauge assembly	140221	140221	A66
Leg extension package for 55 gallon drum	140257	140257	A66
Leg extension stand (only) for 55 gallon drum	140185	140185	A66
Lid assembly (only) for 55 gallon drum	140155	140155	A66
Photohelic automatic cleaning system	140900	141900	A66
Photohelic automatic cleaning system with leg extension	141901	141902	A66
Sound attenuator/damper, 600 CFM (85dBA)	140361	140361	A66

Dust Collector Options for DCM-200A(900 CFM)			
Bag shaker, automatic electric, 115 volts	140340	140390	A65
Bag shaker, automatic pneumatic	140683	140684	A65
HEPA filter	140215	140215	A65
HEPA filter, pressure differential gauge assembly	140221	140221	A65
Leg extension package for 16 gallon drum	140182	140181	A65
Leg extension package for 55 gallon drum	140256	140256	A65
Leg extension stand (only) for 16 gallon drum	140185	140185	A65
Leg extension stand (only) for 55 gallon drum	140180	140180	A65
Lid assembly and drum, 16 gallon	113015	113015	A65
Lid assembly (only) for 55 gallon drum	140255	140255	A65
Manometer, measures pressure differential	140344	140398	A65
Minihelic gauge, measures pressure differential	140841	140842	A65
Sound attenuator/damper, 900 CFM (85dBA)	140769	140769	A65

Dust Collector Options for CDC-9 (900 CFM)			
HEPA filter	140215	140215	A66
HEPA filter, pressure differential gauge assembly	140221	140221	A66
Leg extension package for 55 gallon drum	140257	140257	A66
Leg extension stand (only) for 55 gallon drum	140185	140185	A66
Lid assembly (only) for 55 gallon drum	140155	140155	A66
Photohelic automatic cleaning system	140900	141900	A66
Photohelic automatic cleaning system with leg extension	141901	141902	A66
Sound attenuator/damper, 900 CFM (85dBA)	140769	140769	A66

Higher Volume Ventilation Options			
1200 CFM equipment	Call factory	Call factory	—





3674 Cabinets including FaStrip® (900 CFM)

	FACTORY INSTALLED	CUSTOMER INSTALLED	SEE PAGE
--	----------------------	-----------------------	-------------

Three-Phase Electrical Options (900 CFM)

Single Source:

208 Volt, 60 Hertz	139052	139127	A36
230 Volt, 60 Hertz	139053	139128	A36
460 Volt, 60 Hertz	139054	139129	A36
575 Volt, 60 Hertz	139055	139130	A36
380 Volt, 50 Hertz	139056	139131	A36

Cabinet Extended-Wear Options

Black curtain for cone	140693	510853	A59
Black curtains for front wall	140694	510854	A59
Black curtains for interior sides and back wall	140692	510855	A59
Conveying hose, heavy duty, 6" x 12'	140339	140355	A67
White curtain for cone	140886	140885	A59
White curtains for front wall	140967	140968	A59
White curtains for interior sides and back wall	140888	140887	A59
Window protector, plastic	509191	509191	A64
Window protector, screen	509201	509201	A64

Reclaimer Extended-Wear Options (900 CFM)

Ultrawear lining	526193	N/A	A67
Wear plate	514491	514521	A67

Cabinet Options

2'n'1 door basket, coated	140404	140405	A58
2'n'1 door basket, standard (uncoated)	140342	140406	A58
Antistatic strap	510411	510411	A58
Armrest assembly	140596	140596	A58
Door locking clamp, right side with timer	140628	140630	A58
Door locking clamp, right side without timer	140624	140626	A58
Door locking clamp, two doors with timer	140629	140631	A58
Door locking clamp, two doors without timer	140625	140627	A58
Glove hole plugs	140623	140622	A58
HEPA filter, cabinet inlet	140190	140190	A58
Magnetic separator (included with FaStrip®)	511572	511572	A58
Oscillator assembly (specify horizontal or vertical)	140424	140402	A59
Safety matting (specify length)	509002	509002	A60
Sound attenuator	140597	140597	—
System security key-lock	140864	140864	A60
Timer package, electric	140536	140535	A60
Timer package, mechanical	140420	140421	A60
Turntable, manual, 18" stationary	140422	140422	A60
Turntable, manual, 18" stationary, low profile	140574	140574	A60
Turntable, manual, 24" rolling, includes inside/outside tracks	140322	140322	A60
Turntable, manual, 24" stationary, low profile	140502	140502	A60
Turntable, powered, 24" rolling, includes inside/outside tracks (Consult factory!)	140364	140364	A60
Turntable, powered, 24" stationary, low profile	140504	140504	A60
Vertical door	140490	140490	A63
Vibrating reclaimer screen assembly (included with FaStrip®)	140335	140419	A64

continued on next page



Options: Pro-Finish® Systems

3674 Cabinets including FaStrip®—continued

	FACTORY INSTALLED	CUSTOMER INSTALLED	SEE PAGE
--	----------------------	-----------------------	-------------

Pressure Cabinet Options

Blast hose, 1/2", top entry	140878	140879	A49
Blast hose, 3/4", top entry, with 1/4" Di-Carb™ nozzle	140635	140634	A68
Boron restrictor for MG-78 valve	290184	290184	A50
Cone, 60 degree, for pressure vessel	505002	140060	A68
Constant pressure control assembly	140523	Call Factory	A68
Door sill package for one door	140726	761561	A69
Fine tuning package with choke	140509	140510	A69
Media regulator, aerated	140374	140360	A70
Media sensor, low level	140381	Call Factory	A70
MG-78 CR valve (included with FaStrip®)	290234	290232	A71
Nozzle, 3/16" boron	502032	502032	A49
Nozzle, 3/16" Di-Carb™	501282	501282	A49
Nozzle holder, fixed	140401	140401	A71
Nozzles, second nozzle upgrade	140605	140604	A72
Pressure vessel, 3.5 cubic-foot assembly	140610	140608	A74
Sight glasses for 1.5 cubic-foot pressure vessel (two required)	545471	545471	A72
Sight glasses for 3.5 cubic-foot pressure vessel (two required)	545493	545493	A72
Sure-Flo® valve, automatic (included with FaStrip®)	290188	290188	A73

Suction Cabinet Options

Gun holder, fixed	140400	140400	A75
Gun package, four gun upgrade (adds three guns)	140349	140353	A75
Gun package, three gun upgrade (adds two guns)	140348	140352	A75
Gun package, two gun upgrade (adds one gun)	140347	140351	A75
KLEEN™ package	140357	140392	A75
Nozzle, 5/16" boron	502081	502081	A57
Nozzle, 5/16" Di-Carb™	501341	501341	A57

Dust Collector Options for DCM-200A(900 CFM)

Bag shaker, automatic electric, 115 volts	140340	140390	A65
Bag shaker, automatic pneumatic	140683	140684	A65
HEPA filter	140215	140215	A65
HEPA filter, pressure differential gauge assembly	140221	140221	A65
Leg extension package for 16 gallon drum	140182	140181	A65
Leg extension package for 55 gallon drum	140256	140256	A65
Leg extension stand (only) for 16 gallon drum	140185	140185	A65
Leg extension stand (only) for 55 gallon drum	140180	140180	A65
Lid assembly and drum, 16 gallon	113015	113015	A65
Lid assembly (only) for 55 gallon drum	140255	140255	A65
Manometer, measures pressure differential	140344	140398	A65
Minihelic gauge, measures pressure differential	140841	140842	A65
Sound attenuator/damper, 900 CFM (85dBA)	140769	140769	A65

Dust Collector Options for CDC-9 (900 CFM)

HEPA filter	140215	140215	A66
HEPA filter, pressure differential gauge assembly	140221	140221	A66
Leg extension package for 55 gallon drum	140257	140257	A66
Leg extension stand (only) for 55 gallon drum	140185	140185	A66
Lid assembly (only) for 55 gallon drum	140155	140155	A66
Photohelic automatic cleaning system	140900	141900	A66
Photohelic automatic cleaning system with leg extension	141901	141902	A66
Sound attenuator/damper, 900 CFM (85dBA)	140769	140769	A66

Higher Volume Ventilation Options

1200 CFM equipment	Call factory	Call factory	—
--------------------	--------------	--------------	---



3696 Twin Cabinets including Ergo-Blast (400 and 600 CFM)

	FACTORY INSTALLED	CUSTOMER INSTALLED	SEE PAGE
--	----------------------	-----------------------	-------------

Two items required for upgrades of both cabinets.

Three-Phase Electrical Options (400 CFM)

Single Source:

208 Volt, 60 Hertz	139042	139117	A36
230 Volt, 60 Hertz	139043	139118	A36
460 Volt, 60 Hertz	139044	139119	A36
575 Volt, 60 Hertz	139045	139120	A36
380 Volt, 50 Hertz	139046	139121	A36

Three-Phase Electrical Options (600 CFM)

Single Source:

208 Volt, 60 Hertz	139047	139122	A36
230 Volt, 60 Hertz	139048	139123	A36
460 Volt, 60 Hertz	139049	139124	A36
575 Volt, 60 Hertz	139050	139125	A36
380 Volt, 50 Hertz	139051	139126	A36

Cabinet Extended-Wear Options

Black curtain for cone	510761	510841	A59
Black curtain for cone, ERGO	510761-ERGO	510841-ERGO	A59
Black curtains for front wall	140640	140641	A59
Black curtains for front wall, ERGO	140640-ERGO	140641-ERGO	A59
Black curtains for interior sides and back wall	510801	510881	A59
Black curtains for interior sides and back wall, ERGO	510801-ERGO	510881-ERGO	A59
Conveying hose, heavy duty, 4" x 9' (600 CFM)	140338	140354	A67
Conveying hose, heavy duty, 6" x 12" (900 CFM)	140339	140355	A67
White curtain for cone	140551	140559	A59
White curtain for cone, ERGO	140551-ERGO	140559-ERGO	A59
White curtains for front wall	140577	140973	A59
White curtains for front wall, ERGO	140577-ERGO	140973-ERGO	A59
White curtains for interior sides and back wall	140555	140563	A59
White curtains for interior sides and back wall, ERGO	140555-ERGO	140563-ERGO	A59
Window protector, plastic	509191	509191	A64
Window protector, mesh screen	509201	509201	A64

Reclaimer Extended-Wear Options (400 CFM)

Wear plate	514471	514501	A67
------------	--------	--------	-----

Reclaimer Extended-Wear Options (600 CFM)

Ultrawear lining	526183	N/A	A67
Wear plate	514481	514511	A67

Cabinet Options

2'n'1 door basket, coated	140404	140405	A58
2'n'1 door basket, standard (uncoated)	140342	140406	A58
Antistatic strap	510411	510411	A58
Armrest assembly (included with Ergo-Blast)	140596	140596	A58
Door locking clamp, right side with timer	140628	140630	A58
Door locking clamp, right side without timer	140624	140626	A58

continued on next page



Options: Pro-Finish® Systems

3696 Twin Cabinets including Ergo-Blast—continued

	FACTORY INSTALLED	CUSTOMER INSTALLED	SEE PAGE
Door locking clamp, two doors with timer	140629	140631	A58
Door locking clamp, two doors without timer	140625	140627	A58
Glove hole plugs	140623	140622	A58
HEPA filter, cabinet inlet	140190	140190	A58
Magnetic separator (included with FaStrip®)	511572	511572	A58
Oscillator assembly (specify horizontal or vertical)	140424	140402	A59
Safety matting (specify length)	509002	509002	A60
Sound attenuator (included with Ergo-Blast)	140597	140597	—
System security key-lock	140864	140864	A60
Timer package, electric	140536	140535	A60
Timer package, mechanical	140420	140421	A60
Turntable, manual, 18" stationary	140422	140422	A60
Turntable, manual, 18" stationary, low profile	140574	140574	A60
Turntable, manual, 24" rolling, includes inside/outside tracks (For single cabinet only.)	140322	140322	A60
Turntable, manual, 24" stationary, low profile	140502	140502	A60
Turntable, powered, 24" stationary, low profile (Consult factory!) (For single cabinet only. Not available with Ergo-Blast)	140504	140504	A60
Vertical door	140490	140490	A63
Vibrating reclaimers screen assembly (included with FaStrip®)	140335	140419	A64

Pressure Cabinet Options

Blast hose, ½", top entry	140878	140879	A49
Blast hose, ¾", top entry, with ¼" Di-Carb™ nozzle	140635	140634	A68
Boron restrictor for MG-78 valve	290184	290184	A50
Cone, 60 degree, for pressure vessel	505002	140060	A68
Constant pressure control assembly	140523	Call Factory	A68
Door sill package for one door (two included with Ergo-Blast)	140726	761561	A69
Fine tuning package with choke	140509	140510	A69
Media regulator, aerated	140374	140360	A70
Media sensor, low level	140381	Call Factory	A70
MG-78 CR valve (included with FaStrip®)	290234	290232	A71
Nozzle, ⅜" boron	502032	502032	A49
Nozzle, ⅜" Di-Carb™	501282	501282	A49
Nozzle holder, fixed	140401	140401	A71
Nozzles, second nozzle upgrade	140605	140604	A72
Pressure vessel, 3.5 cubic-foot assembly	140609	140607	A74
Sight glasses for 1.5 cubic-foot pressure vessel (two required)	545471	545471	A72
Sight glasses for 3.5 cubic-foot pressure vessel (two required)	545493	545493	A72
Sure-Flo® valve, automatic (included with FaStrip®)	290188	290188	A73

Suction Cabinet Options

Gun holder, fixed	140400	140400	A75
Gun package, four gun upgrade (adds three guns)	140349	140353	A75
Gun package, three gun upgrade (adds two guns)	140348	140352	A75
Gun package, two gun upgrade (adds one gun)	140347	140351	A75
KLEEN™ package	140357	140392	A75
Nozzle, ⅜" boron	502081	502081	A57
Nozzle, ⅜" Di-Carb™	501341	501341	A57

continued on next page



Options: Pro-Finish® Systems

3696 Twin Cabinets including Ergo-Blast—continued

	FACTORY INSTALLED	CUSTOMER INSTALLED	SEE PAGE
Dust Collector Options for DCM-80A (400 CFM)			
Bag shaker, automatic electric, 115 volts	140340	140390	A65
Bag shaker, automatic pneumatic	140685	140686	A65
HEPA filter	140215-DCM80A	140215-DCM80A	A65
HEPA filter, pressure differential gauge assembly	140221	140221	A65
Leg extension package for 16 gallon drum	140259	140258	A65
Leg extension package for 55 gallon drum	140170/140255	140170/140255	A65
Leg extension stand (only) for 16 gallon drum	140171	140171	A65
Leg extension stand (only) for 55 gallon drum	140170	140170	A65
Lid assembly and drum, 16 gallon	113015	113015	A65
Lid assembly (only) for 55 gallon drum	140155	140155	A65
Manometer, measures pressure differential	140344	140398	A65
Minihelic gauge, measures pressure differential	140841	140842	A65
Sound attenuator/damper, 400 & 600 CFM (85dBA)	140361	140361	A65

Dust Collector Options for SEM-2 (400 & 600 CFM)			
HEPA filter	141090	Call factory	A66
HEPA filter, pressure differential gauge assembly	140221	140221	A66
Photohelic automatic pulse cleaning system	141810	141811	A66
Sound attenuator/damper, 400 & 600 CFM (85dBA)	140966	140966	A66
Sound attenuator, premium, 400 & 600 CFM (80dBA)	141796	141795	A66

Dust Collector Options for DCM-200 (600 CFM)			
Bag shaker, automatic electric, 115 volts	140340	140390	A65
Bag shaker, automatic pneumatic	140683	140684	A65
HEPA filter	140215	140215	A65
HEPA filter, pressure differential gauge assembly	140221	140221	A65
Leg extension package for 16 gallon drum	140182	140181	A65
Leg extension package for 55 gallon drum	140256	140256	A65
Leg extension stand (only) for 16 gallon drum	140185	140185	A65
Leg extension stand (only) for 55 gallon drum	140180	140180	A65
Lid assembly and drum, 16 gallon	113015	113015	A65
Lid assembly (only) for 55 gallon drum	140255	140255	A65
Manometer, measures pressure differential	140344	140398	A65
Minihelic gauge, measures pressure differential	140841	140842	A65
Sound attenuator/damper, 400 & 600 CFM (85dBA)	140361	140361	A65

Dust Collector Options for CDC-6 (600 CFM)			
HEPA filter	140215	140215	A66
HEPA filter, pressure differential gauge assembly	140221	140221	A66
Leg extension package for 55 gallon drum	140257	140257	A66
Leg extension stand (only) for 55 gallon drum	140185	140185	A66
Lid assembly (only) for 55 gallon drum	140155	140155	A66
Photohelic automatic cleaning system	140900	141900	A66
Photohelic automatic cleaning system with leg extension	141901	141902	A66
Sound attenuator/damper, 600 CFM (85dBA)	140361	140361	A66

Higher Volume Ventilation Options			
900 CFM equipment	Call factory	Call factory	—
1200 CFM equipment	Call factory	Call factory	—





4848 Cabinets including Ergo-Blast and FaStrip® (600 and 900 CFM)

	FACTORY INSTALLED	CUSTOMER INSTALLED	SEE PAGE
Three-Phase Electrical Options (600 CFM)			
Single Source:			
208 Volt, 60 Hertz	139047	139122	A36
230 Volt, 60 Hertz	139048	139123	A36
460 Volt, 60 Hertz	139049	139124	A36
575 Volt, 60 Hertz	139050	139125	A36
380 Volt, 50 Hertz	139051	139126	A36
Three-Phase Electrical Options (900 CFM)			
Single Source:			
208 Volt, 60 Hertz	139052	139127	A36
230 Volt, 60 Hertz	139053	139128	A36
460 Volt, 60 Hertz	139054	139129	A36
575 Volt, 60 Hertz	139055	139130	A36
380 Volt, 50 Hertz	139056	139131	A36
Cabinet Extended-Wear Options			
Black curtain for cone	510771	510851	A59
Black curtain for cone, ERGO	510771-ERGO	510851-ERGO	A59
Black curtains for front wall	140640	140641	A59
Black curtains for front wall, ERGO	140640-ERGO	14064-ERGO	A59
Black curtains for interior sides and back wall	510811	510891	A59
Black curtains for interior sides and back wall, ERGO	510811-ERGO	510891-ERGO	A59
Conveying hose, heavy duty, 4" x 9' (600 CFM)	140338	140354	A67
Conveying hose, heavy duty, 6" x 12' (900 CFM)	140339	140355	A67
White curtain for cone	140552	140560	A59
White curtain for cone, ERGO	140552-ERGO	140560-ERGO	A59
White curtains for front wall	140577	140973	A59
White curtains for front wall, ERGO	140577-ERGO	140973-ERGO	A59
White curtains for interior sides and back wall	140556	140564	A59
White curtains for interior sides and back wall, ERGO	140556-ERGO	140564-ERGO	A59
Window protector, plastic	509191	509191	A64
Window protector, mesh screen	509201	509201	A64
Reclaimer Extended-Wear Options (600 CFM)			
Ultrawear lining	526183	N/A	A67
Wear plate	514481	514511	A67
Reclaimer Extended-Wear Options (900 CFM)			
Ultrawear lining	526193	N/A	A67
Wear plate	514491	514521	A67
Cabinet Options			
2'n*1 door basket, coated	140404	140405	A68
2'n*1 door basket, standard (uncoated)	140342	140406	A68
Antistatic strap	510411	510411	A68
Armrest assembly (included with Ergo-Blast)	140596	140596	A68
Door locking clamp, right side with timer	140628	140630	A68
Door locking clamp, right side without timer	140624	140626	A68

continued on next page



Options: Pro-Finish® Systems

4848 Cabinets including Ergo-Blast and FaStrip® (continued)

	FACTORY INSTALLED	CUSTOMER INSTALLED	SEE PAGE
Door locking clamp, two doors with timer	140629	140631	A68
Door locking clamp, two doors without timer	140625	140627	A68
Glove hole plugs	140623	140622	A68
HEPA filter, cabinet inlet	140190	140190	A68
Magnetic separator (included with FaStrip®)	511572	511572	A68
Oscillator assembly (specify horizontal or vertical)	140424	140402	A69
Safety matting (specify length)	509002	509002	A60
Sound attenuator (included with Ergo-Blast)	140597	140597	—
System security key-lock	140864	140864	A60
Timer package, electric	140536	140535	A60
Timer package, mechanical	140420	140421	A60
Turntable, manual, 18" stationary	140422	140422	A60
Turntable, manual, 18" stationary, low profile	140574	140574	A60
Turntable, manual, 24" rolling, includes inside/outside tracks	140322	140322	A60
Turntable, manual, 24" stationary, low profile	140502	140502	A60
Turntable, manual, 36" rolling, includes inside/outside tracks	140323	140323	A60
Turntable, manual, 36" stationary, low profile	140503	140503	A60
Turntable, powered, 24" rolling, includes inside/outside tracks (Consult factory!)	140364	140364	A60
Turntable, powered, 24" stationary, low profile (not available with Ergo-Blast)	140504	140504	A60
Turntable, powered, 36" rolling, includes inside/outside tracks (Consult factory!)	140365	140365	A60
Turntable, powered, 36" stationary, low profile (not available with Ergo-Blast)	140505	140505	A60
Vertical door	140489	140489	A63
Vibrating reclaiming screen assembly (included with FaStrip®)	140335	140419	A64

Pressure Cabinet Options

Blast hose, 1/2", top entry	140878	140879	A49
Blast hose, 3/4", top entry, with 1/4" Di-Carb™ nozzle	140635	140634	A68
Boron restrictor for MG-78 valve	290184	290184	A50
Cone, 60 degree, for pressure vessel	505002	140060	A68
Constant pressure control assembly	140523	Call factory	A68
Door sill package for one door (two included with Ergo-Blast)	140727	761571	A69
Fine tuning package with choke	140509	140510	A69
Media regulator, aerated	140374	140360	A70
Media sensor, low level	140381	Call factory	A70
MG-78 CR valve (included with FaStrip®)	290234	290232	A71
Nozzle, 3/16" boron	502032	502032	A49
Nozzle, 3/16" Di-Carb™	501282	501282	A49
Nozzle holder, fixed	140401	140401	A71
Nozzles, second nozzle upgrade	140605	140604	A72
Pressure vessel, 3.5 cubic-foot assembly, 600 CFM	140609	140607	A74
Pressure vessel, 3.5 cubic-foot assembly, 900 CFM	140610	140608	A74
Sight glasses for 1.5 cubic-foot pressure vessel (two required)	545471	545471	A72
Sight glasses for 3.5 cubic-foot pressure vessel (two required)	545493	545493	A72
Sure-Flo® valve, automatic (included with FaStrip®)	290188	290188	A73

Suction Cabinet Options

Gun holder, fixed	140400	140400	A75
Gun package, four guns (adds three guns)	140349	140353	A75
Gun package, three guns (adds two guns)	140348	140352	A75
Gun package, two guns (adds one gun)	140347	140351	A75
KLEEN™ package	140358	140393	A75
Nozzle, 5/16" boron	502081	502081	A57
Nozzle, 5/16" Di-Carb™	501341	501341	A57

continued on next page



Options: Pro-Finish® Systems

4848 Cabinets including Ergo-Blast and FaStrip®

(continued)

FACTORY INSTALLED	CUSTOMER INSTALLED	SEE PAGE
-------------------	--------------------	----------

Dust Collector Options for SEM-2 (600 CFM)

HEPA filter	141090	Call factory	A66
HEPA filter, pressure differential gauge assembly	140221	140221	A66
Photohelic automatic pulse cleaning system	141810	141811	A66
Sound attenuator/damper, 600 CFM (85dBA)	140966	140966	A66
Sound attenuator, premium, 600 CFM (80dBA)	141796	141795	A66

Dust Collector Options for DCM-200 (600 CFM)

Bag shaker, automatic electric, 115 volts	140340	140390	A65
Bag shaker, automatic pneumatic	140683	140684	A65
HEPA filter	140215	140215	A65
HEPA filter, pressure differential gauge assembly	140221	140221	A65
Leg extension package for 16 gallon drum	140182	140181	A65
Leg extension package for 55 gallon drum	140256	140256	A65
Leg extension stand (only) for 16 gallon drum	140185	140185	A65
Leg extension stand (only) for 55 gallon drum	140180	140180	A65
Lid assembly and drum, 16 gallon	113015	113015	A65
Lid assembly (only) for 55 gallon drum	140255	140255	A65
Manometer, measures pressure differential	140344	140398	A65
Minihelic gauge, measures pressure differential	140841	140842	A65
Sound attenuator/damper, 400 & 600 CFM (85dBA)	140361	140361	A65

Dust Collector Options for CDC-6 (600 CFM)

HEPA filter	140215	140215	A66
HEPA filter, pressure differential gauge assembly	140221	140221	A66
Leg extension package for 55 gallon drum	140257	140257	A66
Leg extension stand (only) for 55 gallon drum	140185	140185	A66
Lid assembly (only) for 55 gallon drum	140155	140155	A66
Photohelic automatic cleaning system	140900	141900	A66
Photohelic automatic cleaning system with leg extension	141901	141902	A66
Sound attenuator/damper, 600 CFM (85dBA)	140361	140361	A66

Dust Collector Options for DCM-200A(900 CFM)

Bag shaker, automatic electric, 115 volts	140340	140390	A65
Bag shaker, automatic pneumatic	140683	140684	A65
HEPA filter	140215	140215	A65
HEPA filter, pressure differential gauge assembly	140221	140221	A65
Leg extension package for 16 gallon drum	140182	140181	A65
Leg extension package for 55 gallon drum	140256	140256	A65
Leg extension stand (only) for 16 gallon drum	140185	140185	A65
Leg extension stand (only) for 55 gallon drum	140180	140180	A65
Lid assembly and drum, 16 gallon	113015	113015	A65
Lid assembly (only) for 55 gallon drum	140255	140255	A65
Manometer, measures pressure differential	140344	140398	A65
Minihelic gauge, measures pressure differential	140841	140842	A65
Sound attenuator/damper, 900 CFM (85dBA)	140769	140769	A65

Dust Collector Options for CDC-9 (900 CFM)

HEPA filter	140215	140215	A66
HEPA filter, pressure differential gauge assembly	140221	140221	A66
Leg extension package for 55 gallon drum	140257	140257	A66
Leg extension stand (only) for 55 gallon drum	140185	140185	A66
Lid assembly (only) for 55 gallon drum	140155	140155	A66
Photohelic automatic cleaning system	140900	141900	A66
Photohelic automatic cleaning system with leg extension	141901	141902	A66
Sound attenuator/damper, 900 CFM (85dBA)	140769	140769	A66

Higher Volume Ventilation Options

1200 CFM equipment	Call factory	Call factory	—
--------------------	--------------	--------------	---



4848 SafeStrip™ and Single-Pass Models (600 and 900 CFM)

	FACTORY INSTALLED	CUSTOMER INSTALLED	SEE PAGE
--	----------------------	-----------------------	-------------

Three-Phase Electrical Options (600 CFM)

Single Source:

208 Volt, 60 Hertz	139047	139122	A36
230 Volt, 60 Hertz	139048	139123	A36
460 Volt, 60 Hertz	139049	139124	A36
575 Volt, 60 Hertz	139050	139125	A36
380 Volt, 50 Hertz	139051	139126	A36

Three-Phase Electrical Options (900 CFM)

Single Source:

208 Volt, 60 Hertz	139052	139127	A36
230 Volt, 60 Hertz	139053	139128	A36
460 Volt, 60 Hertz	139054	139129	A36
575 Volt, 60 Hertz	139055	139130	A36
380 Volt, 50 Hertz	139056	139131	A36

Cabinet Extended-Wear Options

Black curtain for cone	510771	510851	A59
Black curtains for front wall	140640	140641	A59
Black curtains for interior sides and back wall	510811	510891	A59
Conveying hose, heavy duty, 6" x 9', 600 CFM	140338	140354	A67
Conveying hose, heavy duty, 6" x 12', 900 CFM	140339	140355	A67
White curtain for cone	140552	140560	A59
White curtains for front wall	140577	140973	A59
White curtains for interior sides and back wall	140556	140564	A59
Window protector, plastic	509191	509191	A64
Window protector, screen	509201	509201	A64

Cabinet Options

2'n'1 door basket, coated	140404	140405	A58
2'n'1 door basket, standard (uncoated)	140342	140406	A58
Antistatic strap	510411	510411	A58
Armrest assembly	140596	140596	A58
Blast hose, 1/2", top entry	140878	140879	A49
Blast hose, 3/4", top entry, with 1/4" Di-Carb™ nozzle	140635	140634	A66
Boron restrictor for MG-78 valve (not available with SafeStrip™)	290184	290184	A50
Cone, 60 degree, for pressure vessel (not available with SafeStrip™)	505002	140060	A68
Door locking clamp, right side with timer	140628	140630	A58
Door locking clamp, right side without timer	140624	140626	A58
Door locking clamp, two doors with timer	140629	140631	A58
Door locking clamp, two doors without timer	140625	140627	A58
Door sill package for one door	140726	761561	A69
Glove hole plugs	140623	140622	A58
HEPA filter, cabinet inlet	140190	140190	A58
Media sensor, low level (not available with SafeStrip™)	140361	140361	A70
Nozzle, 3/16" boron	502032	502032	A49
Nozzle, 3/16" Di-Carb™	501282	501282	A49
Nozzle holder, fixed	140401	140401	A71
Oscillator assembly (specify horizontal or vertical)	140424	140402	A59
Safety matting (specify length)	509002	509002	A60
Sight glasses for 1.5 cubic-foot pressure vessel (two required)	545471	545471	A72
Sight glasses for 3.5 cubic-foot pressure vessel (two required)	545493	545493	A72
Sound attenuator	140597	140597	—
System security key-lock	140864	140864	A60
Timer package, electric	140536	140535	A60
Timer package, mechanical	140420	140421	A60
Turntable, manual, 18" stationary	140422	140422	A60
Turntable, manual, 18" stationary, low profile	140574	140574	A60
Turntable, manual, 24" rolling, includes inside/outside tracks	140322	140322	A60

continued on next page



Options: Pro-Finish® Systems

4848 SafeStrip™ and Single-Pass Models

(continued)

	FACTORY INSTALLED	CUSTOMER INSTALLED	SEE PAGE
Turntable, manual, 24" stationary, low profile	140502	140502	A60
Turntable, manual, 36" rolling, includes inside/outside tracks	140323	140323	A60
Turntable, manual, 36" stationary, low profile	140503	140503	A60
Turntable, powered, 24" rolling, includes inside/outside tracks <i>(Consult factory!)</i>	140364	140364	A60
Turntable, powered, 24" stationary, low profile	140504	140504	A60
Turntable, powered, 36" rolling, includes inside/outside tracks <i>(Consult factory!)</i>	140365	140365	A60
Turntable, powered, 36" stationary, low profile	140505	140505	A60
Vertical door	140489	140489	A63

Dust Collector Options for DCM-200 (600 CFM)

Bag shaker, automatic electric, 115 volts	140340	140390	A65
Bag shaker, automatic pneumatic	140683	140684	A65
HEPA filter	140215	140215	A65
HEPA filter, pressure differential gauge assembly	140221	140221	A65
Leg extension package for 16 gallon drum	140182	140181	A65
Leg extension package for 55 gallon drum	140256	140256	A65
Leg extension stand (only) for 16 gallon drum	140185	140185	A65
Leg extension stand (only) for 55 gallon drum	140180	140180	A65
Lid assembly and drum, 16 gallon	113015	113015	A65
Lid assembly (only) for 55 gallon drum	140255	140255	A65
Manometer, measures pressure differential	140344	140398	A65
Minihelic gauge, measures pressure differential	140841	140842	A65
Sound attenuator/damper, 400 & 600 CFM (85dBA)	140361	140361	A65

Dust Collector Options for CDC-6 (600 CFM)

HEPA filter	140215	140215	A66
HEPA filter, pressure differential gauge assembly	140221	140221	A66
Leg extension package for 55 gallon drum	140257	140257	A66
Leg extension stand (only) for 55 gallon drum	140185	140185	A66
Lid assembly (only) for 55 gallon drum	140155	140155	A66
Photohelic automatic cleaning system	140900	141900	A66
Photohelic automatic cleaning system with leg extension	141901	141902	A66
Sound attenuator/damper, 600 CFM (85dBA)	140361	140361	A66

Dust Collector Options for DCM-200A(900 CFM)

Bag shaker, automatic electric, 115 volts	140340	140390	A65
Bag shaker, automatic pneumatic	140683	140684	A65
HEPA filter	140215	140215	A65
HEPA filter, pressure differential gauge assembly	140221	140221	A65
Leg extension package for 16 gallon drum	140182	140181	A65
Leg extension package for 55 gallon drum	140256	140256	A65
Leg extension stand (only) for 16 gallon drum	140185	140185	A65
Leg extension stand (only) for 55 gallon drum	140180	140180	A65
Lid assembly and drum, 16 gallon	113015	113015	A65
Lid assembly (only) for 55 gallon drum	140255	140255	A65
Manometer, measures pressure differential	140344	140398	A65
Minihelic gauge, measures pressure differential	140841	140842	A65
Sound attenuator/damper, 900 CFM (85dBA)	140769	140769	A65

Dust Collector Options for CDC-9 (900 CFM)

HEPA filter	140215	140215	A66
HEPA filter, pressure differential gauge assembly	140221	140221	A66
Leg extension package for 55 gallon drum	140257	140257	A66
Leg extension stand (only) for 55 gallon drum	140185	140185	A66
Lid assembly (only) for 55 gallon drum	140155	140155	A66
Photohelic automatic cleaning system	140900	141900	A66
Photohelic automatic cleaning system with leg extension	141901	141902	A66
Sound attenuator/damper, 900 CFM (85dBA)	140769	140769	A66

Higher Volume Ventilation Options

1200 CFM equipment	Call factory	Call factory	—
--------------------	--------------	--------------	---



Options: Pro-Finish® Systems

6060 Cabinets including Ergo-Blast and FaStrip® (900 CFM)

FACTORY
INSTALLED

CUSTOMER
INSTALLED

SEE
PAGE

Three-Phase Electrical Options (900 CFM)

Single Source:

208 Volt, 60 Hertz	139052	139127	A36
230 Volt, 60 Hertz	139053	139128	A36
460 Volt, 60 Hertz	139054	139129	A36
575 Volt, 60 Hertz	139055	139130	A36
380 Volt, 50 Hertz	139056	139131	A36

Cabinet Extended-Wear Options

Black curtain for cone	510781	510861	A59
Black curtain for cone, ERGO	510781-ERGO	510861-ERGO	A59
Black curtains for front wall	140638	140639	A59
Black curtains for front wall, ERGO	140638-ERGO	140639-ERGO	A59
Black curtains for interior sides and back wall	510921	510901	A59
Black curtains for interior sides and back wall, ERGO	510921-ERGO	510901-ERGO	A59
Conveying hose, heavy duty, 6" x 12' (900 CFM)	140339	140355	A67
White curtain for cone	140553	140561	A59
White curtain for cone, ERGO	140553-ERGO	140561-ERGO	A59
White curtains for front wall	140977	140976	A59
White curtains for front wall, ERGO	140977-ERGO	140976-ERGO	A59
White curtains for interior sides and back wall	140557	140565	A59
White curtains for interior sides and back wall, ERGO	140557-ERGO	140565-ERGO	A59
Window protector, plastic	509191	509191	A64
Window protector, mesh screen	509201	509201	A64

Reclaimer Extended-Wear Options (900 CFM)

Ultrawear lining	526193	N/A	A67
Wear plate	514491	514521	A67

Cabinet Options

2'n*1 door basket, coated	140404	140405	A58
2'n*1 door basket, standard (uncoated)	140342	140406	A58
Antistatic strap	510411	510411	A58
Armrest assembly (included with Ergo-Blast)	140596	140596	A58
Door locking clamp, right side with timer	140628	140630	A58
Door locking clamp, right side without timer	140624	140626	A58
Door locking clamp, two doors with timer	140629	140631	A58
Door locking clamp, two doors without timer	140625	140627	A58
Glove hole plugs	140623	140622	A58
Magnetic separator (included with FaStrip®)	511572	511572	A58
Oscillator assembly (specify horizontal or vertical)	140424	140402	A59
Safety matting (specify length)	509002	509002	A60
Sound attenuator (included with Ergo-Blast)	140597	140597	—
System security key-lock	140864	140864	A60
Timer package, electric	140536	140535	A60
Timer package, mechanical	140420	140421	A60
Turntable, manual, 18" stationary	140422	140422	A60
Turntable, manual, 18" stationary, low profile	140574	140574	A60
Turntable, manual, 24" rolling, includes inside/outside tracks	140324	140324	A60
Turntable, manual, 24" stationary, low profile	140502	140502	A60
Turntable, manual, 36" rolling, includes inside/outside tracks	140325	140325	A60
Turntable, manual, 36" stationary, low profile	140503	140503	A60
Turntable, powered, 24" rolling, includes inside/outside tracks (Consult factory!)	140375	140375	A60
Turntable, powered, 24" stationary, low profile (not available with Ergo-Blast)	140504	140504	A60
Turntable, powered, 36" rolling, includes inside/outside tracks (Consult factory!)	140376	140376	A60

continued on next page



Options: Pro-Finish® Systems

6060 Cabinets including Ergo-Blast and FaStrip®

(continued)

	FACTORY INSTALLED	CUSTOMER INSTALLED	SEE PAGE
Turntable, powered, 36" stationary, low profile (not available with Ergo-Blast)	140505	140505	A60
Vertical door	140488	140488	A63
Vibrating reclamer screen assembly (included with FaStrip®)	140335	140419	A64

Pressure Cabinet Options

Blast hose, 1/2", top entry	140878	140879	A49
Blast hose, 3/4", top entry, with 1/4" Di-Carb™ nozzle	140635	140634	A68
Boron restrictor for MG-78 valve	290184	290184	A50
Cone, 60 degree, for pressure vessel	505002	140060	A68
Constant pressure control assembly	140523	Call factory	A68
Door sill package for one door (two included with Ergo-Blast)	140728	761581	A69
Fine tuning package with choke	140509	140510	A69
Media regulator, aerated	140374	140360	A70
Media sensor, low level	140381	Call factory	A70
MG-78 CR valve (included with FaStrip®)	290234	290232	A71
Nozzle, 3/16" boron	502032	502032	A49
Nozzle, 3/16" Di-Carb™	501282	501282	A49
Nozzle holder, fixed	140401	140401	A71
Nozzles, second nozzle upgrade	140605	140604	A72
Pressure vessel, 3.5 cubic-foot assembly, 900 CFM	140610	140608	A74
Sight glasses for 1.5 cubic-foot pressure vessel (two required)	545471	545471	A72
Sight glasses for 3.5 cubic-foot pressure vessel (two required)	545493	545493	A72
Sure-Flo® valve, automatic (included with FaStrip®)	290188	290188	A73

Suction Cabinet Options

Gun holder, fixed	140400	140400	A75
Gun package, four guns (adds three guns)	140349	140353	A75
Gun package, three guns (adds two guns)	140348	140352	A75
Gun package, two guns (adds one gun)	140347	140351	A75
KLEEN™ package	140359	140394	A75
Nozzle, 5/16" boron	502081	502081	A57
Nozzle, 5/16" Di-Carb™	501341	501341	A57

Dust Collector Options for DCM-200A(900 CFM)

Bag shaker, automatic electric, 115 volts	140340	140390	A65
Bag shaker, automatic pneumatic	140683	140684	A65
HEPA filter	140215	140215	A65
HEPA filter, pressure differential gauge assembly	140221	140221	A65
Leg extension package for 16 gallon drum	140182	140181	A65
Leg extension package for 55 gallon drum	140256	140256	A65
Leg extension stand (only) for 16 gallon drum	140185	140185	A65
Leg extension stand (only) for 55 gallon drum	140180	140180	A65
Lid assembly and drum, 16 gallon	113015	113015	A65
Lid assembly (only) for 55 gallon drum	140255	140255	A65
Manometer, measures pressure differential	140344	140398	A65
Minihelic gauge, measures pressure differential	140841	140842	A65
Sound attenuator/damper, 900 CFM (85dBA)	140769	140769	A65

Dust Collector Options for CDC-9 (900 CFM)

HEPA filter	140215	140215	A66
HEPA filter, pressure differential gauge assembly	140221	140221	A66
Leg extension package for 55 gallon drum	140257	140257	A66
Leg extension stand (only) for 55 gallon drum	140185	140185	A66
Lid assembly (only) for 55 gallon drum	140155	140155	A66
Photohelic automatic cleaning system	140900	141900	A66
Photohelic automatic cleaning system with leg extension	141901	141902	A66
Sound attenuator/damper, 900 CFM (85dBA)	140769	140769	A66

Higher Volume Ventilation Options

1200 CFM equipment	Call factory	Call factory	—
--------------------	--------------	--------------	---

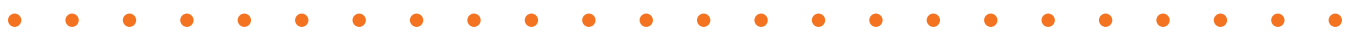



6060 SafeStrip™ and Single-Pass Models (900 CFM)

	FACTORY INSTALLED	CUSTOMER INSTALLED	SEE PAGE
Three-Phase Electrical Options (900 CFM)			
Single Source:			
208 Volt, 60 Hertz	139052	139127	A36
230 Volt, 60 Hertz	139053	139128	A36
460 Volt, 60 Hertz	139054	139129	A36
575 Volt, 60 Hertz	139055	139130	A36
380 Volt, 50 Hertz	139056	139131	A36
Cabinet Extended-Wear Options			
Black curtain for cone	510781	510861	A59
Black curtains for front wall	140638	140639	A59
Black curtains for interior sides and back wall	510921	510901	A59
Conveying hose, heavy duty, 6" x 12', 900 CFM	140339	140355	A59
White curtain for cone	140553	140561	A59
White curtains for front wall	140977	140976	A59
White curtains for interior sides and back wall	140557	140565	A59
Window protector, plastic	509191	509191	A64
Window protector, screen	509201	509201	A64
Cabinet Options			
2'n'1 door basket, coated	140404	140405	A58
2'n'1 door basket, standard (uncoated)	140342	140406	A58
Antistatic strap	510411	510411	A58
Armrest assembly	140596	140596	A58
Blast hose, 1/2", top entry	140878	140879	A49
Blast hose, 3/4", top entry, with 1/4" Di-Carb™ nozzle	140635	140634	A66
Boron restrictor for MG-78 valve (not available with SafeStrip™)	290184	290184	A50
Cone, 60 degree, for pressure vessel (not available with SafeStrip™)	505002	140060	A68
Door locking clamp, right side with timer	140628	140630	A58
Door locking clamp, right side without timer	140624	140626	A58
Door locking clamp, two doors with timer	140629	140631	A58
Door locking clamp, two doors without timer	140625	140627	A58
Door sill package for one door	140728	761581	A69
Glove hole plugs	140623	140622	A58
HEPA filter, cabinet inlet	140752	140752	A58
Media sensor, low level (not available with SafeStrip™)	140361	140361	A70
Nozzle, 3/16" boron	502032	502032	A49
Nozzle, 3/16" Di-Carb™	501282	501282	A49
Nozzle holder, fixed	140401	140401	A71
Oscillator assembly (specify horizontal or vertical)	140424	140402	A59
Safety matting (specify length)	509002	509002	A60
Sight glasses for 1.5 cubic-foot pressure vessel (two required)	545471	545471	A72
Sight glasses for 3.5 cubic-foot pressure vessel (two required)	545493	545493	A72
Sound attenuator	140597	140597	—
System security key-lock	140864	140864	A60
Timer package, electric	140536	140535	A60
Timer package, mechanical	140420	140421	A60
Turntable, manual, 18" stationary	140422	140422	A60
Turntable, manual, 18" stationary, low profile	140574	140574	A60
Turntable, manual, 24" rolling, includes inside/outside tracks	140324	140324	A60

continued on next page



Options: Pro-Finish® Systems

6060 SafeStrip™ and Single-Pass Models—continued

	FACTORY INSTALLED	CUSTOMER INSTALLED	SEE PAGE
Turntable, manual, 24" stationary, low profile	140502	140502	A60
Turntable, manual, 36" rolling, includes inside/outside tracks	140325	140325	A60
Turntable, manual, 36" stationary, low profile	140503	140503	A60
Turntable, powered, 24" rolling, includes inside/outside tracks (Consult factory!)	140375	140375	A60
Turntable, powered, 24" stationary, low profile	140504	140504	A60
Turntable, powered, 36" rolling, includes inside/outside tracks (Consult factory!)	140376	140376	A60
Turntable, powered, 36" stationary, low profile	140505	140505	A60
Vertical door	140488	140488	A63

Dust Collector Options for DCM-200A(900 CFM)

Bag shaker, automatic electric, 115 volts	140340	140390	A65
Bag shaker, automatic pneumatic	140683	140684	A65
HEPA filter	140215	140215	A65
HEPA filter, pressure differential gauge assembly	140221	140221	A65
Leg extension package for 16 gallon drum	140182	140181	A65
Leg extension package for 55 gallon drum	140256	140256	A65
Leg extension stand (only) for 16 gallon drum	140185	140185	A65
Leg extension stand (only) for 55 gallon drum	140180	140180	A65
Lid assembly and drum, 16 gallon	113015	113015	A65
Lid assembly (only) for 55 gallon drum	140255	140255	A65
Manometer, measures pressure differential	140344	140398	A65
Minihelic gauge, measures pressure differential	140841	140842	A65
Sound attenuator/damper, 900 CFM (85dBA)	140769	140769	A65

Dust Collector Options for CDC-9 (900 CFM)

HEPA filter	140215	140215	A66
HEPA filter, pressure differential gauge assembly	140221	140221	A66
Leg extension package for 55 gallon drum	140257	140257	A66
Leg extension stand (only) for 55 gallon drum	140185	140185	A66
Lid assembly (only) for 55 gallon drum	140155	140155	A66
Photohelic automatic cleaning system	140900	141900	A66
Photohelic automatic cleaning system with leg extension	141901	141902	A66
Sound attenuator/damper, 900 CFM (85dBA)	140769	140769	A66

Higher Volume Ventilation Options

1200 CFM equipment	Call factory	Call factory	—
--------------------	--------------	--------------	---

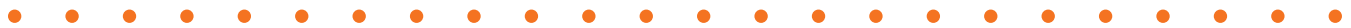



Options: Pro-Finish® Systems

60120 Twin Cabinets (900 CFM)

FACTORY
INSTALLED

CUSTOMER
INSTALLED

SEE
PAGE

Two items required for upgrades of both cabinets.

Three-Phase Electrical Options (900 CFM)

Single Source:

208 Volt, 60 Hertz	139052	139127	A36
230 Volt, 60 Hertz	139053	139128	A36
460 Volt, 60 Hertz	139054	139129	A36
575 Volt, 60 Hertz	139055	139130	A36
380 Volt, 50 Hertz	139056	139131	A36

Cabinet Extended-Wear Options

Black curtain for cone	510781	510861	A59
Black curtain for cone, ERGO	510781-ERGO	510861-ERGO	—
Black curtains for front wall	140638	140639	A59
Black curtains for front wall, ERGO	140638-ERGO	140639-ERGO	—
Black curtains for interior sides and back wall	510921	510901	A59
Black curtains for interior sides and back wall, ERGO	510921-ERGO	510901-ERGO	—
Conveying hose, heavy duty, 6" x 12' (900 CFM)	140339	140355	A67
White curtain for cone	140553	140561	A59
White curtain for cone, ERGO	140553-ERGO	140561-ERGO	—
White curtains for front wall	140977	140976	A59
White curtains for front wall, ERGO	140977-ERGO	140976-ERGO	—
White curtains for interior sides and back wall	140557	140565	A59
White curtains for interior sides and back wall, ERGO	140557-ERGO	140565-ERGO	—
Window protector, plastic	509191	509191	A64
Window protector, mesh screen	509201	509201	A64

Reclaimer Extended-Wear Options (900 CFM)

Ultrawear lining	526193	N/A	A67
Wear plate	514491	514521	A67

Cabinet Options

2'n'1 door basket, coated	140404	140405	A58
2'n'1 door basket, standard (uncoated)	140342	140406	A58
Antistatic strap	510411	510411	A58
Armrest assembly (included with Ergo-Blast)	140596	140596	A58
Door locking clamp, right side with timer	140628	140630	A58
Door locking clamp, right side without timer	140624	140626	A58
Door locking clamp, two doors with timer	140629	140631	A58
Door locking clamp, two doors without timer	140625	140627	A58
Glove hole plugs	140623	140622	A58
HEPA filter, cabinet inlet	140752	140752	A58
Magnetic separator (included with FaStrip®)	511572	511572	A58
Oscillator assembly (specify horizontal or vertical)	140424	140402	A59
Safety matting (specify length)	509002	509002	A60
Sound attenuator (included with Ergo-Blast)	140597	140597	—
System security key-lock	140864	140864	A60
Timer package, electric	140536	140535	A60
Timer package, mechanical	140420	140421	A60
Turntable, manual, 18" stationary	140422	140422	A60
Turntable, manual, 18" stationary, low profile	140574	140574	A60
Turntable, manual, 24" rolling, includes inside/outside tracks	140324	140324	A60
Turntable, manual, 24" stationary, low profile	140502	140502	A60
Turntable, manual, 36" rolling, includes inside/outside tracks	140325	140325	A60
Turntable, manual, 36" stationary, low profile	140503	140503	A60
Turntable, powered, 24" stationary, low profile (Consult factory!)	140504	140504	A60
Turntable, powered, 36" stationary, low profile (Consult factory!)	140505	140505	A60
Vertical door	140488	140488	A63
Vibrating reclaimer screen assembly (included with FaStrip®)	140335	140419	A64

continued on next page



Options: Pro-Finish® Systems

60120 Cabinets—continued

	FACTORY INSTALLED	CUSTOMER INSTALLED	SEE PAGE
Pressure Cabinet Options			
Blast hose, ½", top entry	140878	140879	A49
Blast hose, ¾", top entry, with ¼" Di-Carb™ nozzle	140635	140634	A68
Boron restrictor for MG-78 valve	290184	290184	A50
Cone, 60 degree, for pressure vessel	505002	140060	A68
Constant pressure control assembly	140523	Call Factory	A68
Door sill package for one door (two included with Ergo-Blast)	140728	761581	A69
Fine tuning package with choke	140509	140510	A69
Media regulator, aerated	140374	140360	A70
Media sensor, low level	140381	Call Factory	A70
MG-78 CR valve (included with FaStrip®)	290234	290232	A71
Nozzle, ⅜" boron	502032	502032	A49
Nozzle, ⅜" Di-Carb™	501282	501282	A49
Nozzle holder, fixed	140401	140401	A71
Nozzles, second nozzle upgrade	140605	140604	A72
Pressure vessel, 3.5 cubic-foot assembly, 900 CFM	140610	140608	A74
Sight glasses for 1.5 cubic-foot pressure vessel (two required)	545471	545471	A72
Sight glasses for 3.5 cubic-foot pressure vessel (two required)	545493	545493	A72
Sure-Flo® valve, automatic (included with FaStrip®)	290188	290188	A73
Suction Cabinet Options			
Gun holder, fixed	140400	140400	A75
Gun package, four gun upgrade (adds three guns)	140349	140353	A75
Gun package, three gun upgrade (adds two guns)	140348	140352	A75
Gun package, two gun upgrade (adds one gun)	140347	140351	A75
KLEEN™ package	140359	140394	A75
Nozzle, ⅝" boron	502081	502081	A57
Nozzle, ⅝" Di-Carb™	501341	501341	A57
Dust Collector Options for DCM-200A(900 CFM)			
Bag shaker, automatic electric, 115 volts	140340	140390	A65
Bag shaker, automatic pneumatic	140683	140684	—
HEPA filter	140215	140215	A65
HEPA filter, pressure differential gauge assembly	140221	140221	A65
Leg extension package for 16 gallon drum	140182	140181	—
Leg extension package for 55 gallon drum	140256	140256	—
Leg extension stand (only) for 16 gallon drum	140185	140185	—
Leg extension stand (only) for 55 gallon drum	140180	140180	—
Lid assembly and drum, 16 gallon	113015	113015	—
Lid assembly (only) for 55 gallon drum	140255	140255	—
Manometer, measures pressure differential	140344	140398	A65
Minihelic gauge, measures pressure differential	140841	140842	—
Sound attenuator/damper, 900 CFM (85dBA)	140769	140769	—
Dust Collector Options for CDC-9 (900 CFM)			
HEPA filter	140215	140215	A66
HEPA filter, pressure differential gauge assembly	140221	140221	A66
Leg extension package for 55 gallon drum	140257	140257	—
Leg extension stand (only) for 55 gallon drum	140185	140185	—
Lid assembly (only) for 55 gallon drum	140155	140155	—
Photohelic automatic cleaning system	140900	141900	A66
Photohelic automatic cleaning system with leg extension	141901	141902	—
Sound attenuator/damper, 900 CFM (85dBA)	140769	140769	—
Higher Volume Ventilation Options			
1200 CFM equipment	Call factory	Call factory	—



Pro-Finish® Parts

Pro-Finish® Electrical Options

Electrical Requirements

Pro-Finish® systems are wired to interface with the electrical sources described immediately below.

System Airflow	Horsepower	Nominal Voltage/Frequency
400 CFM	1 hp	115V/60Hz/1Ph
600 CFM	1½ hp	230V/60Hz/1Ph (3 wire)
900 CFM	2 hp	230V/60Hz/1Ph (3 wire)
1,200 CFM	5 hp	230-460V/50* -60Hz/3Ph (3 wire)
1,200 CFM	7½ hp	230-460V/50* -60Hz/3Ph (3 wire)

* 50 Hertz systems with reclaimers may not convey heavier media, especially when using multiple guns, large nozzles and at high altitudes. Consult factory.

IMPORTANT! Systems must be wired at the factory to match the customer's electrical supply. If the electrical supply at the installation site differs from those listed above, specify the appropriate part number(s) shown on the next two pages.

Three-Phase Options

Three-phase electrical options are available in two variations:

Single source packages, including a three-phase blower, a motor starter, a transformer and enclosures, and Empire's **Industrial Electrical Package (I.E.P.)** conform to NFPA 79 Electrical Standard for Industrial Machinery. The many safety and convenience features in the I.E.P. include:

- Control transformer
- I.E.C. motor starter with overload relay
- Fuse protected wiring
- NEMA 12 enclosures with panels
- Three-phase blower motor (3600 RPM)
- Green, oil-tight ON push button
- Red, oil-tight OFF mushroom-head push button
- Labels for panel-mounted devices
- Machine nameplate
- Allen-Bradley components where applicable

If customer's specification differs from the I.E.P. described above, send the specification to our Modified Cabinet Department for evaluation and a price quotation.

Part Numbers for Three-Phase Options

NOMINAL VOLTAGE/FREQUENCY	208V/60Hz	230V/60Hz	460V/60Hz	575V/60Hz	380V/50Hz*
400 CFM/1 Horsepower	PART NUMBERS				
Single source, Factory installed	139042	139043	139044	139045	139046
Single source, Customer installed†	139117	139118	139119	139120	139121
Industrial Equipment Package (I.E.P.)	139057	139058	139059	139096	NA
600 CFM/1½ Horsepower					
Single source, Factory installed	139047	139048	139049	139050	139051
Single source, Customer installed†	139122	139123	139124	139125	139126
Industrial Equipment Package (I.E.P.)	139060	139061	139062	139097	NA
900 CFM/2 Horsepower					
Single source, Factory installed	139052	139053	139054	139055	139056
Single source, Customer installed†	139127	139128	139129	139130	139135
Industrial Equipment Package (I.E.P.)	139063	139064	139065	139098	NA
1200 CFM/5 Horsepower					
Single source, Factory installed	139088	139089	139090	139091	139092
Single source, Customer installed†	139132	139089	139133	139130	139131
Industrial Equipment Package (I.E.P.)	139093	139140	139095	139099	NA
1200 CFM/7½ Horsepower					
Single source, Factory installed	NA	NA	139316	NA	NA

* 50 Hertz systems with reclaimers may not convey heavier media, especially when using multiple guns, large nozzles and at high altitudes. Consult factory.

† Customer installed part numbers apply if machine now has standard wiring. Customer installation is not recommended. Electrical parts are not returnable.

continued on next page

Never use silica sand in any Empire equipment.



Parts: Pro-Finish® Electrical Options

Part Numbers for Single-Phase Options

PART FUNCTION/DESCRIPTION	FACTORY INSTALLED PART NUMBER	CUSTOMER INSTALLED PART NUMBER
400 CFM/1 HP connection to 110V/50Hz*/1Ph supply requires:		
50 Hertz motor	139138	NA
400 CFM/1 HP connection to 220V/50Hz*/1Ph supply requires:		
50 Hertz motor for 3-wire supply	139039	NA
Add Transformer .5KVA for 2-wire supply†	139115	NA
400 CFM/1 HP connection to 230V/60Hz/1Ph (3 wire) supply requires:		
Rewiring	139038	140474**
600 CFM/1½ HP connection to 115V/60Hz/1Ph supply requires 30 Amp service :		
Contactors & Rewiring	139110	139111**
600 CFM/1½ HP connection to 220V/50Hz*/1Ph supply requires:		
50 Hertz motor for 3-wire supply	139040	NA
Add Transformer .5KVA for 2-wire supply†	139115	NA
900 CFM/2 HP connection to 115V/60Hz/1Ph supply requires 30 Amp service :		
Contactors & Rewiring	139110	139111**
900 CFM/2 HP connection to 220V/50Hz*/1Ph supply requires:		
50 Hertz motor for 3-wire supply	139041	NA
Add Transformer .5KVA for 2-wire supply†	139115	NA

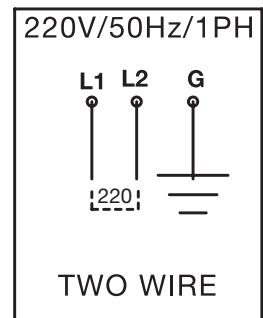
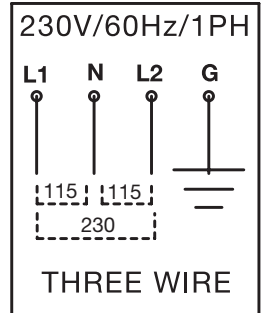

* 50 Hertz systems with reclaimers may not convey heavier media, especially when using multiple guns, large nozzles and at high altitudes. Consult factory.

† Add **PN 139116** (1.0KVA Transformer upgrade) instead of PN 139115 if cabinet is equipped with a **2"n"1 door-basket attachment** (PNs 140342 or 140404).

** Customer installed part numbers apply if machine now has standard wiring. Customer installation is not recommended. Electrical parts are not returnable.

Dual Station Cabinets

Order two of each part number if option is required at both stations.

NOTES on Electrical Components

- If no electrical disconnect is provided, the customer is responsible for providing appropriate disconnecting means adjacent to this equipment for each incoming power circuit. Each disconnect shall be of a type and rating suitable for the application. Refer to current editions of the **National Electrical Code (NFPA 70)** and the **Electrical Standard for Industrial Machinery (NFPA 79)**. Systems with a line cord plug do not require a disconnect. A disconnect is standard with Empire's **Industrial Electrical Package**.
- Interconnections between cabinet, dust collector and customer's utilities are to be supplied by installer.
- Some Pro-Finish options use separate 115 volt line cords with plugs.
- Electrical components cannot be returned to the factory for exchange.
- 50 Hertz systems with reclaimers may not convey heavier media, especially when using multiple guns, large nozzles, and at high altitudes. Consult factory.
- All three-phase systems are **three wire** (three-phase conductors and a ground).
- Consult factory for other electrical options, for conformance with customer electrical specifications, or if you have questions.

See Operating Instructions for Proper Electrical Connection

Electrical connection at installation should be performed by a competent licensed electrician following local codes, standard safety procedures and proper installation instructions.

Never use silica sand in any Empire equipment.



Parts: Pro-Finish® Cabinet Assemblies

Guide to Part Numbers

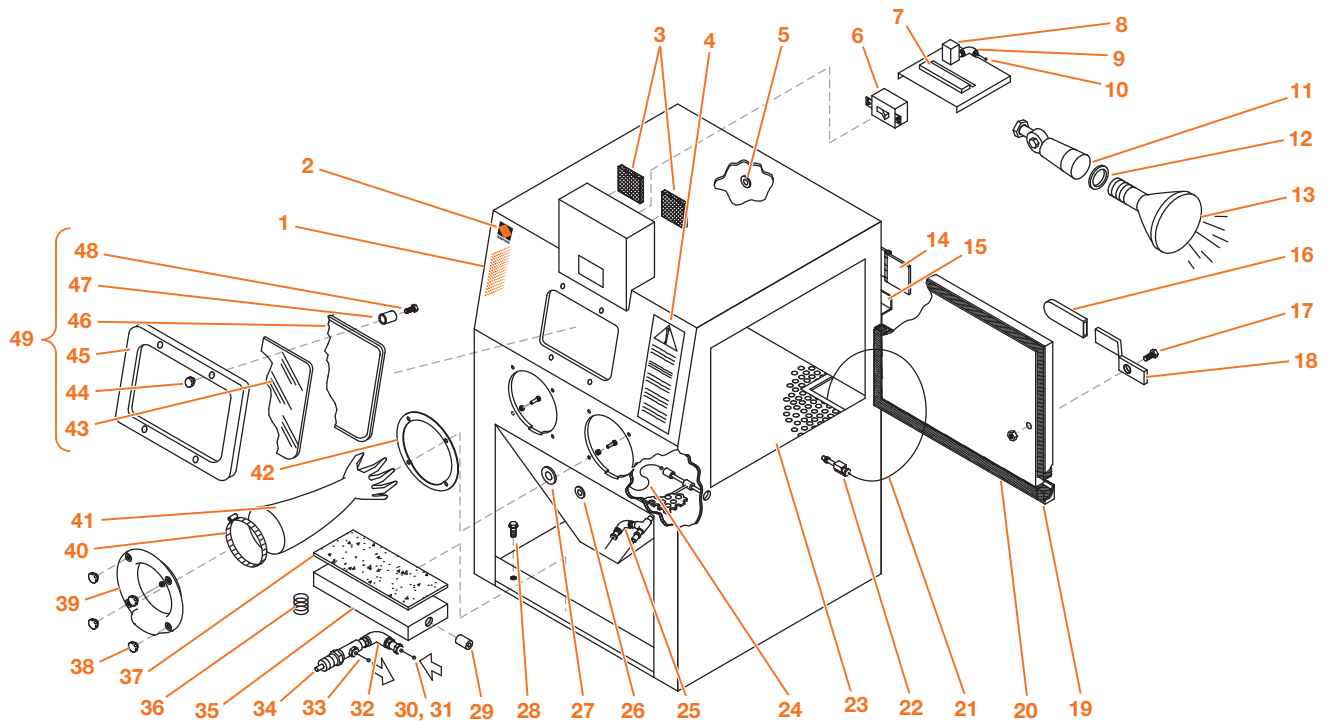

PRO-FINISH CABINET ASSEMBLY COMPONENTS		CABINET SIZE					
		2636	3648 3696	3660	3674	4848	6060 60120
Item	Description	PART NUMBERS					
1	Decal, orange dot strip (specify length)	564301	564301	564302	564301	564301	564302
	<i>Length in inches</i>	24"	30"	45"	30"	30"	45"
2	Paint, touch-up kit	564476	564476	564476	564476	564476	564476
3	Filter, Kleensweep™ inlet (2 required)	510491	510491	510491	510491	510491	510491
4	Decal, Instruction/Warnings	567391	567391	567391	567391	567391	567391
5	Grommet, blast hose, 1" x 1 3/8"	523931	523931	523931	523931	523931	523931
6	Switch, On/Off, 20 amp	534561	534561	534561	534561	534561	534561
7	Terminal strip, 15 pole	533611	533611	533611	533611	533611	533611
8	Solenoid valve, standard and CSA	519001	519001	519001	519001	519001	519001
9	Adapter, 1/4" tube x 1/8" MPT, 90°	520432	520432	520432	520432	520432	520432
10	Tubing, 1/4" OD (specify length)	510541	510541	510541	510541	510541	510541
11	Light fixture	532711	532711	532711	532711	532711	532711
12 *	Gasket, light bulb, 1 per bulb	580191	580191	580191	580191	580191	580191
13 †	Floodlight bulb	532701	532701	532701	532701	532701	532701
	Light guard (not shown)	509481	509481	509481	509481	509481	509491
	Light bar (not shown)	NA	NA	NA	NA	NA	770941
14	Hinge, 3"	509531	509531	509531	509531	509531	509531
15	Z-strip (reclaimer mount not shown)	760151	760161	760161	760161	760161	760171
16	Cover, handle	509571	509571	509571	509571	509571	509571
17	Bolt, door, 3/8"-16 x 2" SHCS	552151	552151	552151	552151	552151	552151
	Nut, 3/8"-16 ESNA	553952	553952	553952	553952	553952	553952
18	Handle, door	760361	760361	760361	760361	760361	760971
	Tie bar (not shown)	NA	NA	NA	NA	NA	760401
	Keeper (not shown)	760371	760371	760371	760371	760371	760371
19 †	Bumper, urethane	525041	525041	525041	525041	525041	525041
*	Gasket, 3/4" x 3/4"	525671	525681	525681	525681	525691	525701
20		(7', 2")	(10', 4")	(10', 4")	(10', 4")	(12', 7")	(15', 0")
*	Gasket, 3/4" x 3/4" (specify length)	524441	524441	524441	524441	524441	524441



Parts: Pro-Finish® Cabinet Assemblies

PRO-FINISH CABINET ASSEMBLY COMPONENTS		CABINET SIZE					
		2636	3648 3696	3660	3674	4848	6060 60120
Item	Description	PART NUMBERS					
21	Hose with fittings, dust-off gun	522631	522641	522661	526641	521481	522661
22	Gun, dust-off	509821	509821	509821	509821	509821	509821
	Spring (not shown)	511251	511251	511251	511251	511251	511251
23	Floor section, 2 required (4 needed for 3696 & 60120)	760541	760551	760571	760555	760561	760571
24	Interlock hose assembly: 3/8" air hose with clamps	520003	520003	520004	520003	520003	520004
25	Adapter, 1/4" x 1/8" MPT, 90°	520432	520432	520432	520432	520432	520432
26	Grommet, dust-off hose, 1/4" - 5/8" x 7/8"	523951	523951	523951	523951	523951	523951
27	Grommet, suction air hose, 3/4" x 1 1/16"	523921	523921	523921	523921	523921	523921
	Hole seal (pressure only)	536391	536391	536391	536391	536391	536391
28	Leveling bolt, 3/8" - 16 x 2" (4 required)	551742	551742	551742	551742	551742	551742
29	Brass bushing, treadle (2 required)	510501	510501	510501	510501	510501	510501
30	Tubing, 1/4" OD (specify length)	510541	510541	510541	510541	510541	510541
31	Connector, 1/8" MPT x 1/4" tube	520252	520252	520252	520252	520252	520252
32	Elbow, 1/8"	543822	543822	543822	543822	543822	543822
33	Barbed PTC, 1/4" tube x #10 - 32	521101	521101	521101	521101	521101	521101
34	† Valve, foot treadle, 3"	517221	517221	517221	517221	517221	517221
	† Barbed fitting, 1/4" tube x #10 - 32 with gasket	521101	521101	521101	521101	521101	521101
35	Foot treadle base	760041	760041	760041	518651	760041	760041
36	† Spring, treadle return (2 required)	510421	510421	510421	—	510421	510421
37	Grip/cover, treadle	524391	524391	524391	—	524391	524391
	Foot treadle assembly (includes items 29 through 37)	140160	140160	140160	140579**	140160	140160
Glove ring upgrade (includes items 38, 39, 42 and hardware)		140015	140015	140015	140015	140015	140015
38	Knob, 3/8" - 16 (4 required)	510461	510461	510461	510461	510461	510461
39	Glove flange	555036	555036	555036	555036	555036	555036
40	Clamp, 8", per glove	520561	520561	520561	520561	520561	520561
41 *	Gloves, pair	509891	509891	509891	509891	509891	509891
	Glove, left hand	510821	510821	510821	510821	510821	510821
42	Gasket, glove ring	523321	523321	523321	523321	523321	523321
43 *Δ	Safety glass, 14" x 22"	510401	510401	510401	510401	510401	510401
44	Knob, 3/8" - 16 (4 required)	510461	510461	510461	510461	510461	510461
45	Frame, window	760291	760291	760291	760291	760291	760291
	† Gasket, window, 6' section	524451	524451	524451	524451	524451	524451
46	Gasket, 1/4" x 1/4" (specify length)	525941	525941	525941	525941	525941	525941
	Gasket, 1/8" x 1/4" (specify length)	523551	523551	523551	523551	523551	523551
47	Spacer, window (4 required)	525931	525931	525931	525931	525931	525931
48	Bolt, 3/8" - 16 x 1 1/4"	551852	551852	551852	551852	551852	551852
49	Window kit (includes items 43 through 48)	140544	140544	140544	140544	140544	140544

* Recommended spare part—Consumable wear item

† Essential component to prevent downtime

** See Page A40, Item 1, for more information.

Δ Failure to replace glass with Empire safety glass could result in serious injury.



Parts: Pro-Finish® Ergo-Blast Cabinet Assemblies

Ergo-Blast cabinets share most of the components shown on pages Pages A38 and A39 with other Pro-Finish® models. Ergo-Blast differences are shown below.

Guide to Part Numbers

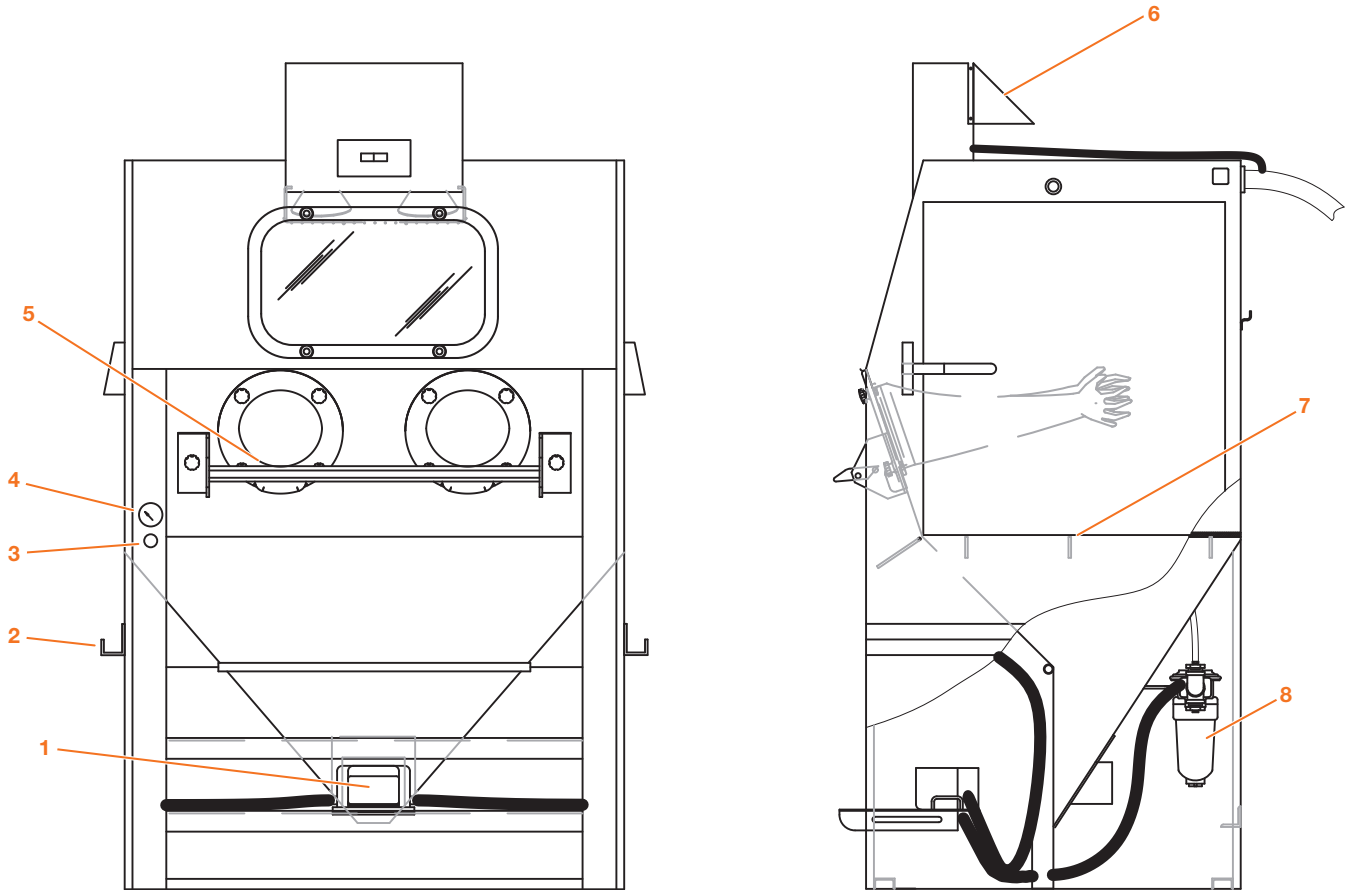

ERGO-BLAST CABINET ASSEMBLIES/PART VARIATIONS		CABINET SIZE				
		2636	3648 3696	3660	4848	6060
Item	Description	PART NUMBERS				
1	Foot treadle	518651	518651	518651	518651	518651
	Valve for foot treadle	518661	518661	518661	518661	518661
	Foot treadle assembly	140579	140579	140579	140579	140579
	Repair kit	518671	518671	518671	518671	518671
2	Door sill package for 1 door	140725	140726	140726	140727	140728
3	Pressure regulator	517613	517613	517613	517613	517613
4	Pressure gauge	550212	550212	550212	550212	550212
5	Arm rest assembly	140595	140596	140596	140596	140596
6	Cabinet sound attenuator	140597	140597	140597	140597	140597
7	Floor section (2 required)	770191	770201	770213	770211	760572
8	Pipe string assembly	(See page A47 for detail.)				

Parts: Pro-Finish® Reclaimers

Guide to Part Numbers

PRO-FINISH RECLAIMER COMPONENTS		400	600	900
Airflow Capacity (CFM)				1200
Item	Description	PART NUMBER		
1	Reclaimer body assembly (includes items 1 through 13)	140439	140440	140441
	Body assembly w/ 1 hp, 115V, 60Hz/1ph blower & bag	140438	NA	NA
2	Gasket, outlet flange (1 required)	524361	NA	NA
3	Outlet flange (6")	751501	NA	NA
4 *	Removable top	NA	766741	766751
5 †	Gasket, ¼" x ¼" poron PSA (specify length)	-	525941	525941
6 †	Gasket, reclaimer door	524331	524331	524331
7	Door, reclaimer	760721	760721	760721
8	Wing nut, ¼" - 20	552392	552392	552392
9 †	Gasket, reclaimer to storage hopper	524371	524371	524371
10 †	Gasket, tuning band, solid	524342	524342	524342
	Gasket, tuning band, with slots	524341	524341	524341
11	Tuning band (steel part only), solid	767581	767581	767581
	Tuning band (steel part only), with slots	760701	760701	760701
12	Bolt, ¼" - 20 x 2"	551782	551782	551782
13	Latch & keeper (requires welding)	509581	509581	509581
14	Screen, flat, 5/16", 13" OD	760711	760711	760711
15	Screen, fine 11½" OD, 8 mesh	739041	739041	739041
	Screen, 11½" OD, 4 mesh	739051	739051	739051
16	Bolt, 3/8" - 16 x 1" (8 required)	551852	551852	551852
17 *	Exhaust hose assembly for 1 cu. ft. pressure vessel (For pressure systems only)	522611	522611	522611
18	Plug, 1" NPT (For suction systems only)	544122	544122	544122

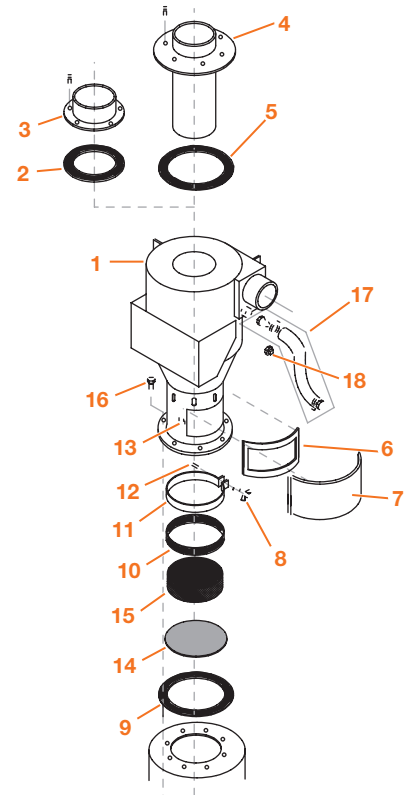

Reclaimer Options

Ultrawear lining	NA	526183	526193
Inlet wear plate (complete)			
FACTORY INSTALLED	514471	514481	514491
CUSTOMER INSTALLED	514501	514511	514521
Inlet wear plate (detail)			
A Rubber band	524871	524881	524891
B Bolt, 3/8" - 16 x 2" (3 required)	553892	553892	553892
C Metal band	761601	761611	761621
D Bolt, 3/8" - 16 x 1½" (3 required)	551262	551262	551262
E Nut, 3/8" - 16	552542	552542	552542

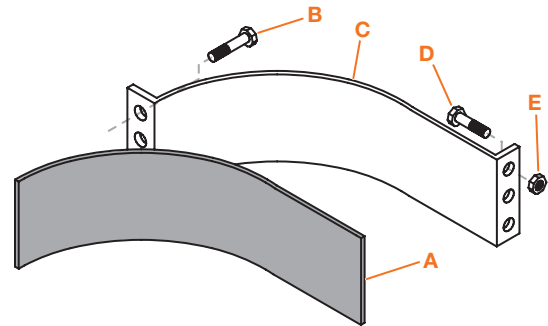

* Recommended spare part—Consumable wear item
 † Essential component to prevent downtime



Parts: Pro-Finish® Dust Collectors, Bag House

Guide to Part Numbers - DCM-80A (#112000), DCR-80 (#112100), DCM-200 (#113000), DCM-200A (#113001) & DCM-200B (#113002)

Item	Description	PART#
1	Bolt, leveling, 3/8" - 16 x 2" (4 required)	553892
2	Latch and keeper (requires welding)	509581
3	Hose with fittings, 1/4" x 16', dust collector	523161
4	Adapter, 1/4" tube x 1/4" MPT (inside)	521081
	Connector, brass, 1/4" MPT x 1/4" BALL (outside)	520222
5	Bolt, 3/8" - 16 x 1 1/4" (6 required)	551852
6	Knob, 3/8" - 16 (6 required)	510461
7	Access door, dust collector	760851
8 †	Gasket, access door, 1/2" x 5/8", 103" section	525711
	Gasket, 1/2" x 5/8" (specify length)	525061
9 †	Valve, push-button, 1/8" NPT & #10 - 32, "3P"	517221
	Barbed fitting, 1/4" tube x #10 - 32, 2 per assembly	521101
	Adapter, 1/4" tube x 1/8" MPT, 90° (for air cylinder)	520432
10	Tubing, 1/4" OD (8' required)	510541
11 †	Air cylinder, standard collector & auto shaker (after 1997)	515981
	Air cylinder, standard collector & auto shaker (before 1997)	515771
	Air cylinder, auto pneumatic bag shaker only	Call
12 †	Gasket, top plate, 1/8" x 1/4" (8' for DCM-80A; 12' for others)	523551
13	Blower & blower motors (See page A45.)	—
	Top plate, DCM-80A	760841
14	Top plate, DCM-200 & DCM-200A	760901
	Top plate, DCM-200B	760187
15	Bag-rack weldment (DCM-80A)	760861
	Bag-rack weldment (DCM-200A)	760921
16	Rubber bumper (8 required)	523541
17 *	Dust bag, cotton sateen (12 required for DCM-80A & DCR-80, 30 required for DCM-200, DCM-200A & DCM-200B)	515521
18	Decal, Instruction/Warning	567405
19	Ducting & adapters (See page A46.)	—
20	Adapter, 10 1/8" ID x 6" OD, DCM-200	761801
21 †	Gasket, clean-out door, dust collector	524351
	Decal, Empire logo	564305
	Decal, orange dot strip	564301
	Paint, 6 oz. aerosol, beige	564476

* Recommended spare part—Consumable wear item

† Essential component to prevent downtime

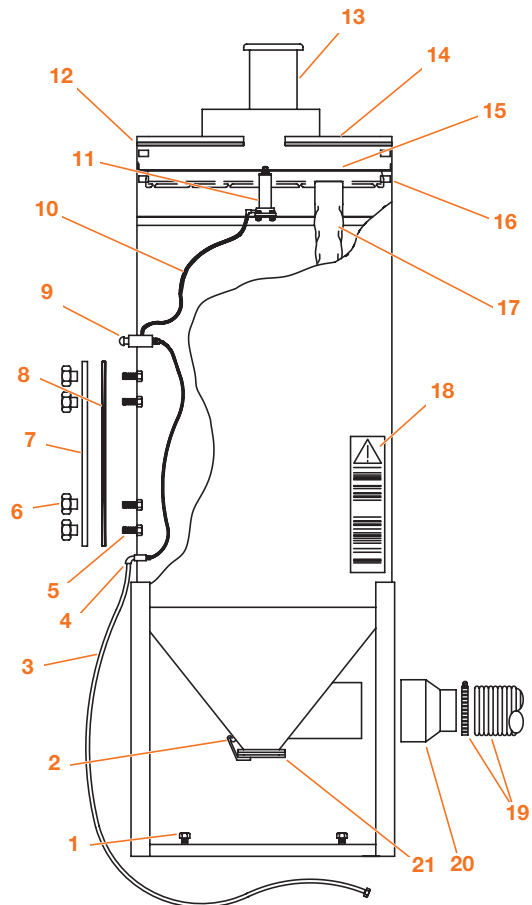

Bag-House Dust Collector Options (Part Numbers)

Automatic bag shaker cleans bags thoroughly every time the system is turned off.

Electric shaker for all bag-house collectors, 115 volts

Pneumatic shaker for DCM-80 series collectors

Pneumatic shaker for DCM-200 series collectors

HEPA filter captures very fine particles.

DCM-80A

DCM-200, 200A, 200B

HEPA filter, pressure differential gauge assembly (magnetic)

Leg extension package for 16 gallon drum

DCM-80A

DCM-200, 200A, 200B

Leg extension package for 55 gallon drum

DCM-80A

DCM-200, 200A, 200B

Leg extension stand (only) for 16 gallon drum

DCM-80A

DCM-200, 200A, 200B

Leg extension stand (only) for 55 gallon drum

DCM-80A

DCM-200, 200A, 200B

Lid assembly for 16 gallon drum fits all Empire bag house collectors

Lid assembly for 55 gallon drum

DCM-80A

DCM-200, 200A, 200B

Manometer measures pressure differential

Minihelic gauge measures pressure differential

Sound attenuator reduces noise in the work place.

Attenuator/damper for DCM-80A & DCM-200

Attenuator/damper for DCM-200A

Attenuator/damper for DCM-200B

SuperSmooth dust bags handle severe dust loading

	FACTORY INSTALLED	CUSTOMER INSTALLED	SEE PAGE
Automatic bag shaker			
Electric shaker	140340	140390	A65
Pneumatic shaker for DCM-80 series collectors	140685	140686	Call
Pneumatic shaker for DCM-200 series collectors	140683	140684	Call
HEPA filter			
DCM-80A	140215-DCM80A	140215-DCM80A	Call
DCM-200, 200A, 200B	140215	140215	Call
HEPA filter, pressure differential gauge assembly (magnetic)	140221	140221	—
Leg extension package for 16 gallon drum			
DCM-80A	140259	140258	Call
DCM-200, 200A, 200B	140182	140181	Call
Leg extension package for 55 gallon drum			
DCM-80A	140170/140255	140170/140255	Call
DCM-200, 200A, 200B	140256	140256	Call
Leg extension stand (only) for 16 gallon drum			
DCM-80A	140171	140171	Call
DCM-200, 200A, 200B	140185	140185	Call
Leg extension stand (only) for 55 gallon drum			
DCM-80A	140170	140170	Call
DCM-200, 200A, 200B	140180	140180	Call
Lid assembly for 16 gallon drum fits all Empire bag house collectors	113015	113015	A65
Lid assembly for 55 gallon drum			
DCM-80A	140155	140155	Call
DCM-200, 200A, 200B	140255	140255	Call
Manometer measures pressure differential	140344	140398	—
Minihelic gauge measures pressure differential	140841	140842	A43
Sound attenuator reduces noise in the work place.			
Attenuator/damper for DCM-80A & DCM-200	140361	140361	—
Attenuator/damper for DCM-200A	140769	140769	—
Attenuator/damper for DCM-200B	140680	140680	—
SuperSmooth dust bags handle severe dust loading	516181	516181	—

Parts: Pro-Finish® Dust Collectors, Cartridge

Guide to Part Numbers

For CDC-6 (PN 113007), CDC-9 (PN 113011) & CDC-12 (PN 113013)

"CDC" SERIES COMPONENTS		
Item	Description	PART#
1	Bolt, leveling, 3/8" - 16 x 2" (4 required)	553892
2	16 gallon drum	504016
3	Lid for 16 gallon drum	850099-1
4	Gasket, dust drum lid, 5' (not shown)	800166
5	Gum rubber tube, 4" ID x 8" long	523750
6	Hose clamp, 4" (2 required)	520531
7	16 gallon drum assembly (includes items 2 through 5)	113015
8	Filter clamping screw	515526
9 †	Gasket, access door, 1/2" x 5/8", 103" section	525711
10	Gasket, 1/2" x 5/8" (specify length)	525061
11	Access door, dust collector	760851
12	Knob, 3/8" - 16 (6 required)	510461
13	Bolt, 3/8" - 16 x 1 1/4" (6 required)	551852
14	Empire logo	564305
15	Blower and blower motors (<i>See page A45.</i>)	—
16	Diaphragm valve (2 required)	516352
17	Top plate, CDC-6	760901
18	Top plate, CDC-9	760901
19	Top plate, CDC-12	760187
20	Air supply assembly	140851
21 *	Cartridge filter (2 required)	515525
22	Decal, Instruction/Warning	567406
23	Mini-Helic package	550450
24	Ducting and adapters (<i>See page A46.</i>)	—
25	Adapter, 10" ID x 6" OD for CDC-6	761801

* Recommended spare part—Consumable wear item

† Essential component to prevent downtime

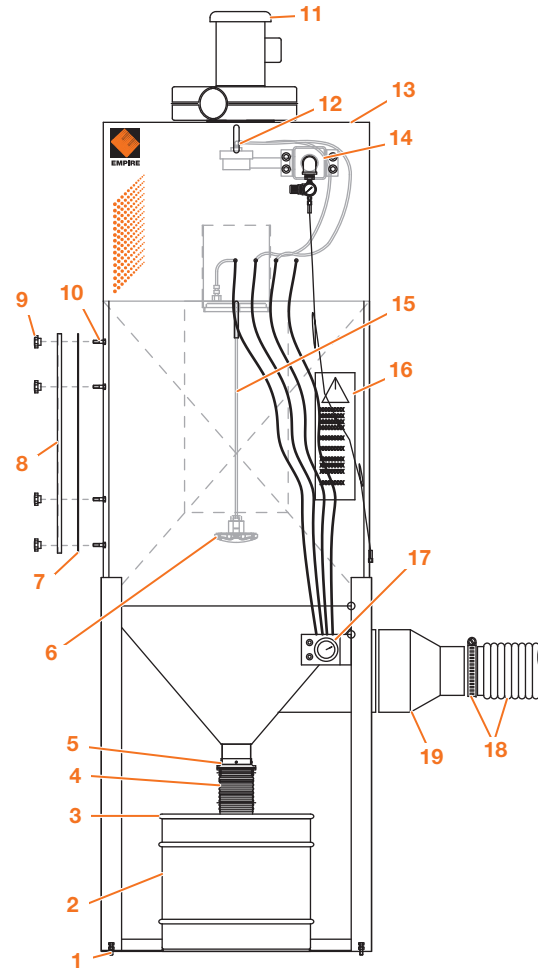

Minihelic Gauge Assembly (Part # 550450)

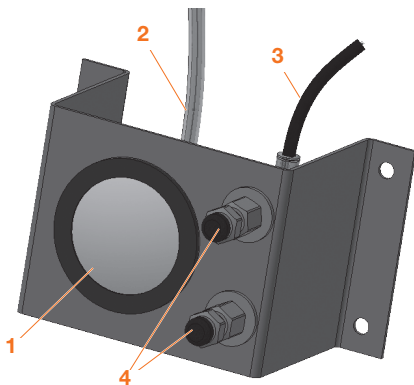

MINIHELIC COMPONENTS		
Item	Description	PART NUMBER
1	Gauge, Minihelic	504201
2	Tubing, clear, 5/16" OD	522433
3	Tubing, black, 1/4" OD	510541
4	Push-button valve	520393

Cartridge Dust Collector Options

	PART NUMBERS		
	FACTORY INSTALLED	CUSTOMER INSTALLED	SEE PAGE
HEPA filter captures very fine particles.	140215	140215	—
HEPA filter, pressure differential gauge assembly (magnetic)	140221	140221	—
Leg extension package for 55 gallon drum	140257	140257	—
Leg extension stand (only) for 55 gallon drum	140185	140185	A65
Lid assembly for 55 gallon drum	140155	140155	A65
Photohelic automatic pulse cleaning system	140900	141900	A66
Photohelic automatic pulse cleaning system with leg extension	141901	141902	—
Sound attenuator reduces blower motor noise to 85dBA			
CDC-6	140361	140361	—
CDC-9	140769	140769	—
CDC-12	140680	140680	—



Parts: Pro-Finish® Dust Collectors, SEM-2

Guide to Part Numbers

SEM-2, 1 HP (PN 113033) & 1½ HP (PN 113032) COMPONENTS

Item	Description	PART #
1	Blower assembly (See page A45.)	—
	Collector assembly	113036
2	Air supply assembly	140851
	Regulator/gauge	517612
3	Clamps	520531
4	Cover	516106
5	Waste pail	509611
6	Dust-drum platform	756682
7 †	Gasket, Neoprene, 9½" ID x 12" OD	515710
8	Gum rubber tube, 4" ID x 4½" long (after 9/09)	523749
	Hose, 7" ID x 6" long (before 9/09)	516104
9 *	Filter assembly (2 required)	523523
10	Stand	770105
	Minihelic package	550450
11	Gauge only	504201
	Push button valve only	520393
	Diaphragm valve, 2 required (not shown)	516343

* Recommended spare part—Consumable wear item

† Essential component to prevent downtime

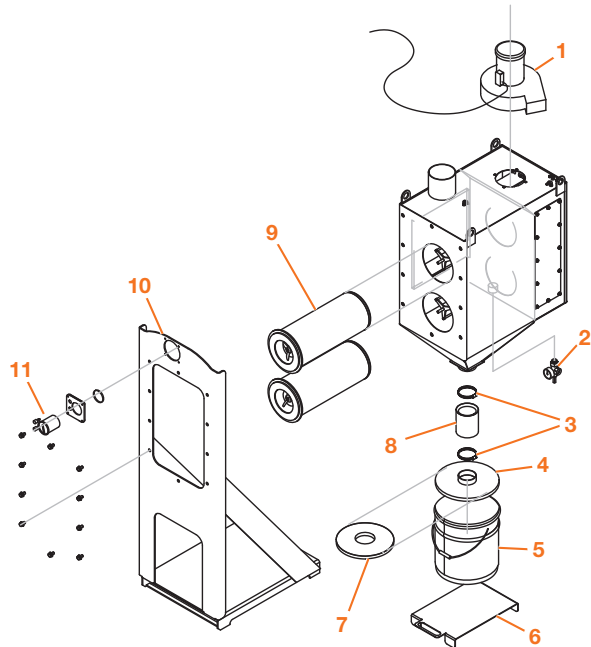

SEM-2 Dust Collector Options

	PART NUMBER	
	FACTORY INSTALLED	CUSTOMER INSTALLED
HEPA filter captures very fine particles	141090	141090
HEPA filter, pressure differential gauge assembly (magnehelic)	140221	140221
Photohelic automatic pulse cleaning system for SEM-2	141810	141811
Sound attenuator/damper, 600 CFM (85dBA)	140966	140966
Sound attenuator, premium, 600 CFM (80dBA)	141796	141795



Parts: Pro-Finish® Dust Bag

Guide to Part Numbers

DUST BAG COMPONENTS

Item	Description	PART NUMBER
1	Clamp, 4" adjustable	520531
2 *	Dust bag, 4" inlet, 30 sq. ft.	515841
3	Closure clamp	520461
	Blower assembly (See page A45.)	—

* Recommended spare part—Consumable wear item

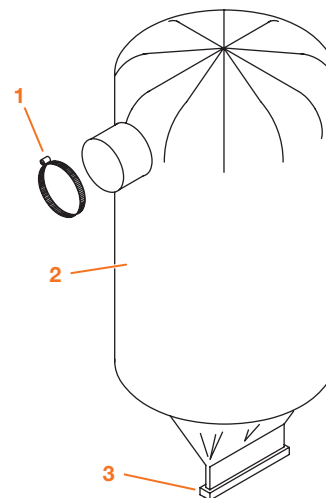



Parts: Pro-Finish® Blowers (Fans & Motors)

Blower Assembly Part Numbers

For Dust Collector Models	Horsepower	Part Number	Standard Electrical	CFM at 6" SP	Notes
Dust bag & DCM-80A, SEM-2	1	140311	115/60/1	400	Bag not included
DCM-200, CDC-6 & SEM	1½	140312	230/60/1	600	6" SP at 600 CFM
DCM-200A & CDC-9	2	140313	230/60/1	900	6" SP at 900 CFM
DCM-200B & CDC-12	5	140651	230/50-60/3	1200	10" SP at 1200 CFM

Note: Motor starters, contactors, interconnecting wiring and ducting not included.

Guide to Component Part Numbers

BLOWER COMPONENTS		PART NUMBERS		
Item	Description	1 HP	1½ HP	2 HP
1 †	Motor, 115-230V, 60 Hz, Single phase	549531	549681	549691
	Motor, 220-480V, 60 Hz, 3 phase	549701	549721	549711
	Motor, 550-600V, 60 Hz, 3 phase	549731	549741	549751
	Motor, 110-220V, 50 Hz, Single phase	549761	549771	549781
Note: Motor part numbers shown in BOLD are supplied as standard most often.				
2	Housing, fan, top	753511	753511	753515
3	Screw, flat head ⅜"-16 x 1"	553271	553271	553271
4	Gasket, fan housing, ⅛" x ¼" (5' section)	523251	523251	523251
5	Screw, flat head ⅜"-16 x 2¼" (dust collector)	553183	553183	553183
6	Gasket, mounting (3 required)	524361	524361	524361
7	Clip, fan guard (4 required)	554431	554431	554431
8	Guard, fan outlet	739011	739011	739025
9	Outlet flange	751501	751501	—
10	Hex nut, ¼"-20	552522	552522	552522
11	Lock washer, ¼"	552752	552752	552752
12	Flat washer, ¼"	552882	552882	552882
13	Housing, fan, bottom	753521	753521	753525
14 †	Impeller (fan blade), 10⅝" dia., ⅝" ID	753021	—	—
	Impeller (fan blade), 11½" dia., ⅝" ID	—	753661	—
	Impeller (fan blade), 12½" dia., ⅝" ID	—	—	753031
15	Bolt, ¼"-20 x 1"	552131	552131	552131

† Essential component to prevent downtime

5 Horsepower Blower Assemblies

• Assembly, complete (230-460V, 60 Hz, 3 phase)	PN 549403
• Motor only (230-460V, 60 Hz, 3 phase)	PN 549963
• Impeller only, (old style) 14"	PN 753041
• Impeller only, (current) 16½"	PN 753051

Call for more information.

7½ Horsepower Blower Assemblies

• Assembly, complete (230-460V, 60 Hz, 3 phase)	PN 360004
• Motor only (230-460V, 60 Hz, 3 phase)	Call factory
• Impeller only (fan blade)	Call factory

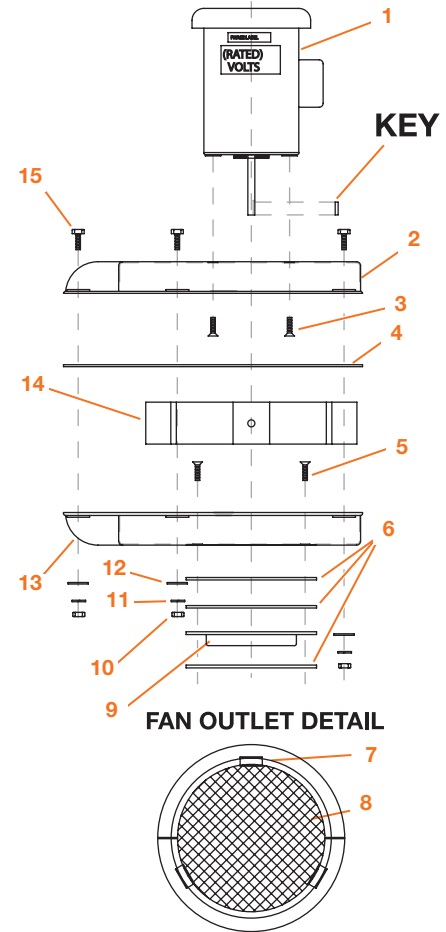



Parts: Pro-Finish® Ducting, Hoses and Adapters

Guide to Part Numbers

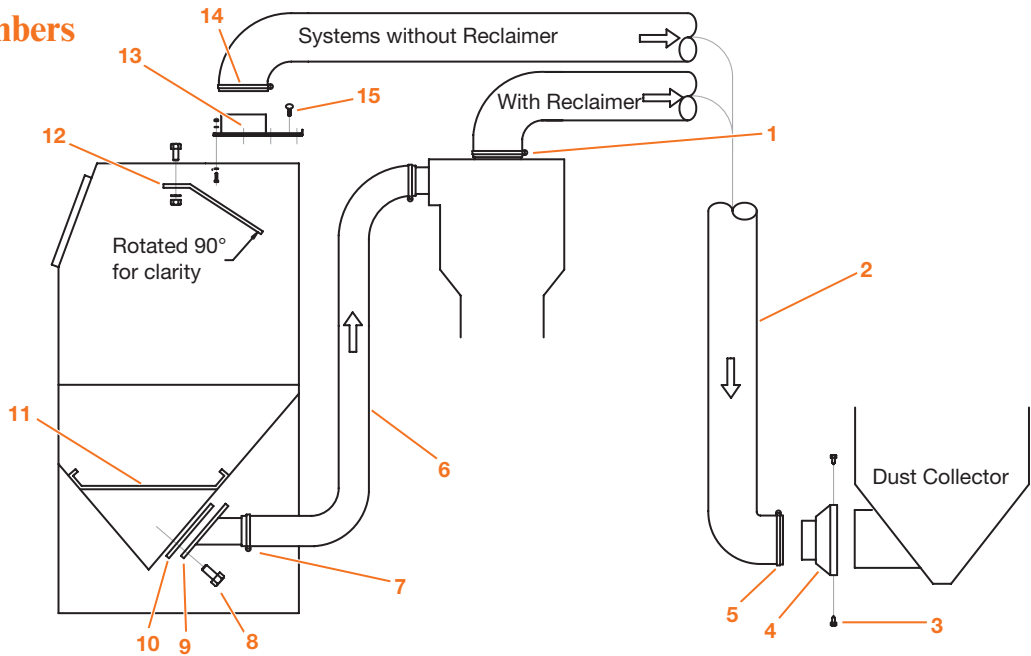

RECLAIMER CAPACITY		400 CFM	600 CFM	900 CFM	1200 CFM
Item	Description	PART NUMBERS			
1	Hose clamp, dust hose (Nominal hose diameter)	520551 (6")	520551 (6")	522314 (10")	522314 (10")
2	Dust hose (I.D. x length)	516101 (6" x 11')	516101 (6" x 11')	516999 (10" x 15')	516999 (10" x 15')
	Dust hose for optional 3.5 ft ³ pressure vessel (I.D. x length)	515631 (6" x 25')	515631 (6" x 25')	516999 (10" x 15')	516999 (10" x 15')
3	Screw, 1/4" - 20 x 1" (3 required)	551560	551560	551560	551560
4	Adapter, dust hose, 6" O.D. x 10 1/8" I.D., DCM-200	NA	761801	NA	NA
5	Hose clamp, dust hose (Nominal hose diameter)	520551 (6")	520551 (6")	522314 (10")	522314 (10")
6	Conveying hose, standard duty, without clamps (I.D. x length)	522351 (4" x 8')	522351 (4" x 8')	516101 (6" x 11')	516101 (6" x 11')
	Conveying hose, heavy duty, with clamps, factory upgrade ** (I.D. x length)	140338 (4" x 9')	140338 (4" x 9')	140339 (6" x 12')	140339 (6" x 12')
	Conveying hose, heavy duty, with clamps, customer install (I.D. x length)	140354 (4" x 9')	140354 (4" x 9')	140355 (6" x 12')	140355 (6" x 12')
	Conveying hose, 4" I.D., heavy duty to length (Specify length)	515911	515911	—	—
	Conveying hose, 6" I.D., heavy duty to length (Specify length)	—	—	515921	515921
	Conveying hose, standard duty, for optional 3.5 ft ³ pressure vessel (I.D. x length)	516033 (4" x 15')	516033 (4" x 15')	516115 (6" x 18')	516115 (6" x 18')
	Conveying hose, heavy duty, for optional 3.5 ft ³ vessel, factory upgrade **	140613 (4" x 18')	140613 (4" x 18')	140614 (6" x 20')	140614 (6" x 20')
Conveying hose, heavy duty, for optional 3.5 ft ³ vessel, customer install (I.D. x length)	140611 (4" x 18')	140611 (4" x 18')	140612 (6" x 20')	140612 (6" x 20')	
7	Hose clamp, standard duty conveying hose	520531	520531	520551	520551
	Hose clamp, heavy duty conveying hose	522953	522953	522963	522963
8	Bolt, 1/4"-20 x 1" (4 required)	551212	551212	551212	551212
9	Outlet adapter, cabinet	760421	760421	760431	760431
10	Gasket, cabinet outlet	524381	524381	524381	524381
11	Screen (2636 & 3648 cabinets)	766771	766771	766771	766771
	Screen (4848 & 6060 cabinets)	NA	766781	766781	766781

Suction Systems with a Dust Collector but without a Reclaimer

12	Baffle, ventilation, all size cabinets	760828
13	Slide gate assembly, system with dust bag	760826
	Slide gate assembly, system with collector	760827
14	Clamp for 6" nominal hose	520551
15	Bolt, 1/4"-20 x 1" (5 required)	553554

Hose Adapters, miscellaneous

10" I.D. x 6" O.D. for DCM 200	761801
6" I.D. x 4" O.D.	764691
6" I.D. x 5" O.D.	509711
5" I.D. x 4" O.D.	511401
6 1/8" I.D. x 5" O.D. with 4 3/4" I.D. fits over 4" HD hose	764032
Block-off plate, outer adapter, seals lower outlet	760451

* Recommended spare part—Consumable wear item ** Not to be ordered as replacement hose.

Parts: Pro-Finish® Pipe Strings

Pipe String Assemblies

Description	PART NUMBER
½" pipe string used with one-gun suction	140279
1" pipe string used with pressure & multi-gun suction	140280
1" pipe string used with Ergo-Blast systems	140479

Pipe String Mounting Hardware

Description	PART NUMBER
¼" flat-head bolt (4 required)	564121
¼" washer (4 required)	552882
¼" hex nut (4 required)	552522

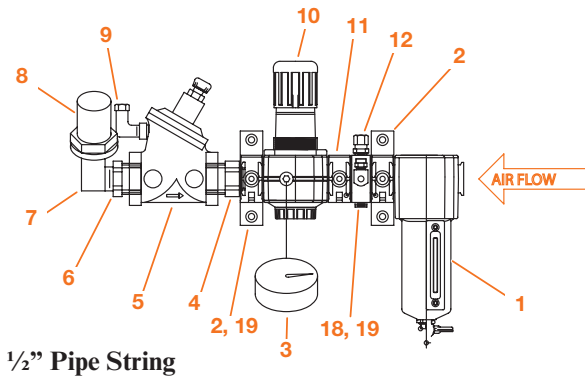

½" Pipe String

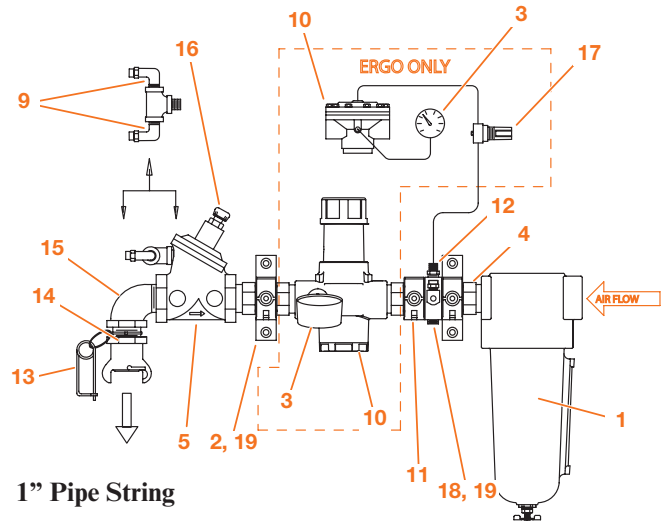

1" Pipe String

Guide to Part Numbers

PIPE STRING COMPONENTS		PART NUMBERS		
Item	Description	½" String	1" String	Ergo String
1 †	Air filter (½" manual, 1" manual; Norgren)	504652	517271	517271
	Element for Norgren air filter, 5µ	508012	508002	508002
	O-ring and gasket kit for Norgren air filter	508112	505161	505161
2	Mounting feet/quick clamp	522155	522155	522155
3	Gauge, (550232, ¼" NPT; 550212, ⅛" NPT back mount used on Ergo models only)	550232	550232	550212
4	Adapter	522156	522156	522156
5 †	Main air valve (1" Aquamatic)	517042	517042	517042
	Diaphragm and seal kit for 1" Aquamatic	517582	517582	517582
	Special wrench for 1" Aquamatic	518512	518512	518512
	Repair kit for 1" Aquamatic	517583	517583	517583
6	Bushing, 1" x ½" brass	544497	—	—
7	Elbow, ½" x 90°	543533	—	—
8	Hose barb, ½"	520362	—	—
9	Adapter, ¼" tube x ⅛" NPT 90°	520432	520432	520432
10 †	Air-pressure regulator (Norgren)	517141	517251	517631
	Diaphragm and O-ring kit for Norgren regulator	508102	508161	508211
11	Quick clamp	522154	522154	522154
12	Hose adapter, ¼" x ¼"	520222	520222	520222
13	Safety pin	—	510511	510511
14	Coupling, 1" FPT, UF-100	—	505782	505782
15	Elbow, 1" NPT street	—	543542	543542
16	Vent	523261	523261	523261
17 †	Regulator, ¼" NPT	—	—	517613
18	Porting block	522157	522157	522157
19	O-ring for modular pipe string	522162	522162	522162

† Essential component to prevent downtime



Parts: Pro-Finish® Pressure Blast Systems

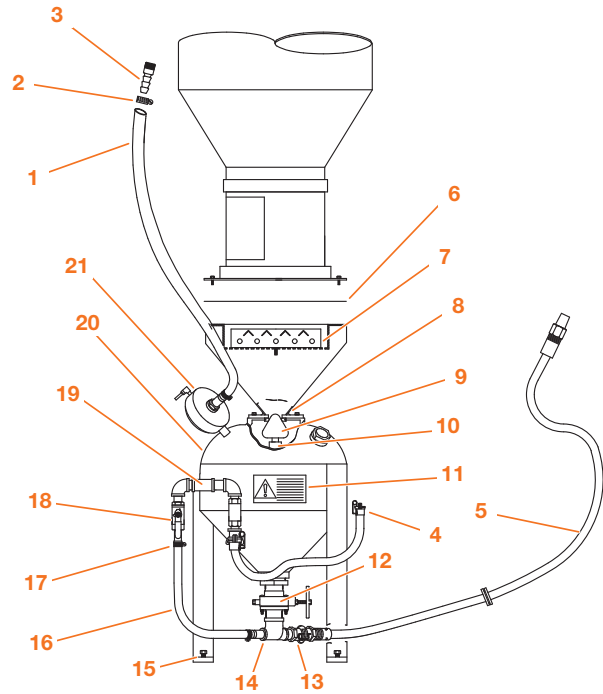

Exhaust Hose

Item	Description	PART NUMBER
1 *	Exhaust hose with 1" NPT barb ends (5'7" for standard 1 cu. ft. pressure vessel)	522611
	Exhaust hose with 1" NPT barb ends (9' for optional 3.5 cu. ft. vessel)	140691
	Exhaust hose, 1" ID (Max. length: 50')	520822
2 †	Hose clamp, 2" (1 each end)	520512
3 *	Hose barb, 1" NPT x 1" ID hose (1 each end)	520181

Blast & Air Hoses

Item	Description	Bulk	PART NUMBERS					
			2636	3648 3696	3674	3660	4848	6060 60120
4 †	Air-hose assembly, 1" ID	—	140301	140302	140302	140303	140303	140304
	(Air-hose length)	—	(4')	(5')	(5')	(6')	(6')	(7')
	Air hose, 1" ID	520912	—	—	—	—	—	—
5 *	Blast hose assembly, ½" ID NC/QC (Nozzle adapter not included)	—	522551	522541	521672	521672	521672	522561
	(Blast hose length except Ergo-Blast & FaStrip)	—	(7'6")	(9')	(10')	(10')	(10')	(13')
5 *	Blast hose assembly, ½" ID, Ergo-Blast (Blast hose length for Ergo-Blast models)	—	521672	516271	516271	516271	522561	522561
	Blast hose, ½" ID, maximum length: 50'	520792	—	—	—	—	—	—

Pressure Vessel

Item	Description	PART NUMBER
6 †	Gasket, reclaimers to hopper	524371
7	Hopper, 1 cubic foot	760741
8 †	Sealing ring, rubber, 2½" ID	523942
9 †	Plunger, sealing, PVC coated	510431
10	Plunger guide, ½" NPT x 3½" nipple	546072
11	Label, WARNING "Do not disassemble . . ."	567332
	Label, WARNING "Flange above . . ."	567312
12	Sure-Flo media regulator, manual (See page A50.)	290383
13	Tank coupling	505782
14	Bullhead tee, 1" x 1" x 2" NPT	545822
15	Leveling bolt, ⅜" - 16 x 3", 1 cu. ft. (3 per assembly)	551902
	Leveling bolt, ½" - 13 x 2¾", 3.5 cu. ft. (3 per assembly)	551982
16	Hose, 1" ID (Specify 1.5' for 1 cu. ft. vessel; 3.5' for 3.5 cu. ft. vessel)	520912
17 †	Hose clamp for 1" ID hose (1 each end)	520581
18	Ball valve, 1" NPT	518492
19	Tee, 1" x 1" x ½" NPT	545702
20	Pressure vessel only, 1 cu. ft.	760811
21	MG-78 exhaust valve (See page A50.)	290182
	Pressure vessel assembly includes items 1 through 3 and 8 through 22.	140300

* Recommended spare part—Consumable wear item † Essential component to prevent downtime



Parts: Pro-Finish® Pressure Blast Systems

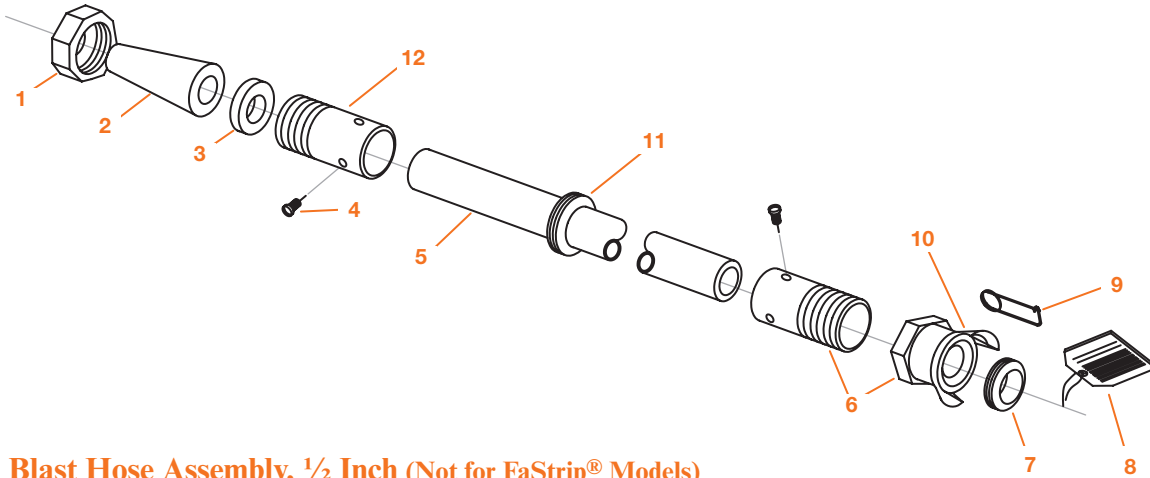

Blast Hose Assembly, 1/2 Inch (Not for FaStrip® Models)

Item	Description	MODEL NUMBER	PART NUMBER
1 †	Nozzle adapter	NA-2	504912
2	Ceramic nozzle, 3/16" (not included)		502362
3	Nozzle washer, Ceramic nozzle 5/8" ID (10 pack)	NW-5	524041
	Nozzle washer, Di-Carb/Boron, 1/2" ID (10 pack)	NW-2	524052
4 †	Screws (4 pack) Δ	#8 x 3/8"	554242
5	Blast hose, 1/2" ID (specify length)	PBH-1/2	520792
6	Quick coupling with washer and screw package	QC-1/2	505222
7	Coupling washer (10 pack)	AHCW	524101
	Coupling washer (25 pack)	AHCW	525102
8	Tag, safety, screw/coupling	—	564822
9 †	Safety pin Δ	—	510511
10	Tank coupling, 1" FPT with AHCW	UF-100	505782
11	Grommet, blast hose	1" x 1 3/4"	523931
12 †	Nozzle coupling and screw package	NC-1/2	505232

Δ **WARNINGS:** See page A55.

Pressure Blast Nozzles

Nozzles for pressure blast systems are available in sizes and materials to meet any application requirement.

Size	MODEL AND PART NUMBERS					
	3/32" (#0)	1/8" (#2)	3/16" (#3)	1/4" (#4)	5/16" (#5)	3/8" (#6)
Ceramic (uses NW-5 washer)	CN3-0	CN3-2	CN3-3	CN3-4	CN3-5	CN3-6
Each	502342	502352	502362	502372	502382	502393
Pack of 10	503372	503382	503392	503402	503412	503422
Pack of 50	503432	503422	503452	503462	503472	503482
Di-Carb™ (comes with NW-2 washer)		DC2F-2	DC2F-3	DC2F-4	DC2F-5	
Each		501272	501282	501292	501302	
Boron (comes with NW-2 washer)		NN2F-2	NN2F-3	NN2F-4	NN2F-5	
Each		502022	502032	502042	502052	

• CN3-3 is standard with 1/2" blast hose • CN3-5 supplied with optional 3/4" blast hose. • Consult factory with special requirements.



Parts: Pro-Finish® Pressure Blast Systems

Manual Sure-Flo® Media Regulator (Part Number 290383)

Item	Description	PART NUMBER
1	Hex nut, 3/8" - 16 (6 required)	552542
2	Lock washer, 3/8" ID (6 required)	552762
3	Hex bolt, 3/8" - 16 x 3" (2 required)	551902
4	Adapter, manual body, Sure-Flo	753372
5	Handle assembly, 1/2" - 13 x 4"	290384
6	Jam nut, 1/2"	552672
7	Carriage bolt, 3/8" - 16 x 2 1/2" (4 required)	552052
8	Flange, 2" MPT	753292
9 †	Roller stop, holder	753092
10	Screw, 8 - 32 x 1/2" (2 per assembly)	551352
11	Bolt, 7/16" - 14 x 1 1/4"	552222
12 †	Pinch roller (2 per assembly)	753632
13	Valve body, 2" MPT	753692
14 *	Metering tube, 3/4" ID (See below.)	523592

* Recommended spare part—Consumable wear item

† Essential component to prevent downtime

Note: These fasteners are used two places to mount manual body adapter to Sure-Flo® body.

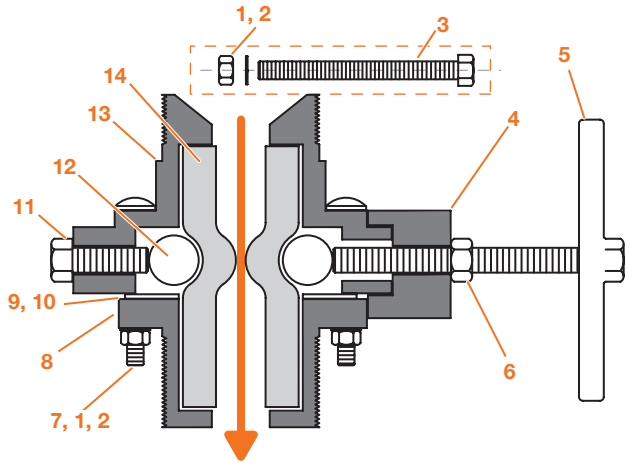

For details on the Automatic Sure-Flo® (PN 290215), see page A73.

Sure-Flo® metering tubes are available in six sizes for work with differing media types and nozzle sizes.

Metering Tube ID	Nozzle Size	Grit Range	Comments	PART NUMBER
3/8"	Small	Fine	Back out roller bolt 1/2"	525451
1/2"	Small-medium	Fine-medium	Back out roller bolt 1/2"	525782
3/4"	Medium-large	Medium	Supplied as standard	523592
3/4"	Medium-large	Medium	Use below 32° F. (red)	523512
5/8"	Medium	Medium-coarse		525792
7/8"	Large	Coarse	For high-production	525802

MG-78 Exhaust Valve

Item	Description	PART #
	Complete assembly with ceramic restrictor kit	290182
	Complete assembly with boron restrictor kit	290582
1	Hose barb, 1"	520181
2	Reducer bushing, 1 1/4" MPT x 1" FPT	544512
3	Valve body	753332
4	Seat, valve ball (steel)	753412
5	Gasket, seat	524132
6	Valve ball	525322
7	Space washer, steel (1/2" ID x 2" OD x 1/4" thick)	553412
8	Spacer ring, outer	753402
9	Bolt, 3/8" - 16 x 2"	553892
	Lock washer, 3/8"	552762
10	Washer (1/2" ID x 2" OD x 1/16" thick)	552842
11	Valve cover	753382
12	Spacer ring, inner	753392
13	Bolt, 1/2" - 13 x 1 3/4"	551962
14	Elbow, brass (1/4" MPT x 1/4" tube)	520242
	Pipe bushing, 1/4" x 1/8"	544302
15	Diaphragm (2 per assembly)	523672
16	Pipe nipple, 1" CLOSE	546192
17	Screws, seat, 1/4" - 20 x 1/2" (pack of 3)	551122

RESTRICTOR PARTS

18	Nozzle washer, NW-4 (pack of 10)	524082
19	Nozzle washer, NW-1 (pack of 10)	524062
20	Steel washer	552952
	Ceramic restrictor kit (standard)	290218
	Ceramic nozzle (standard)	502431
21	Boron carbide restrictor (replacement)	502081
	Boron carbide restrictor kit (factory upgrade)	290184

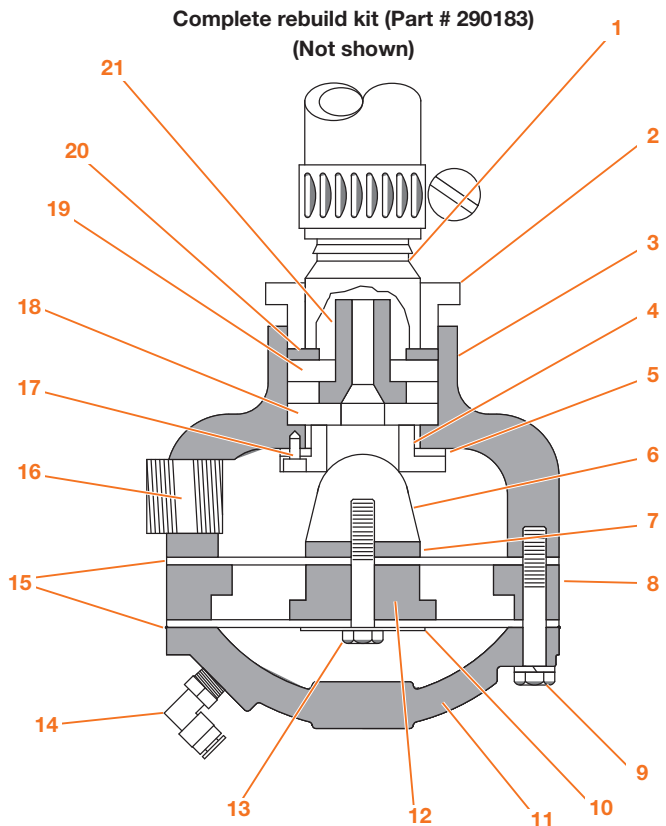



Parts: Pro-Finish® FaStrip® Blast Systems

FaStrip® blast systems share most of the pressure blast components shown on pages A48 through A50 with other Pro-Finish® pressure models. Many features that are optional with other cabinets are standard with FaStrip®.

Standard Features with FaStrip®

Item	PART NUMBERS	
	FACTORY INSTALLED	CUSTOMER INSTALLED
1 Automatic Sure-Flo® media regulator (See page A52.)	290215	290215
2 MG-78 CR exhaust valve (See page A53.)	290234	290232
3 Magnetic separator	511572	511572
4 Vibrating reclaimer screen (See page A53.)	140335	140419
5 Blast hose assembly, 3/4" urethane (See below.)	140648	140648

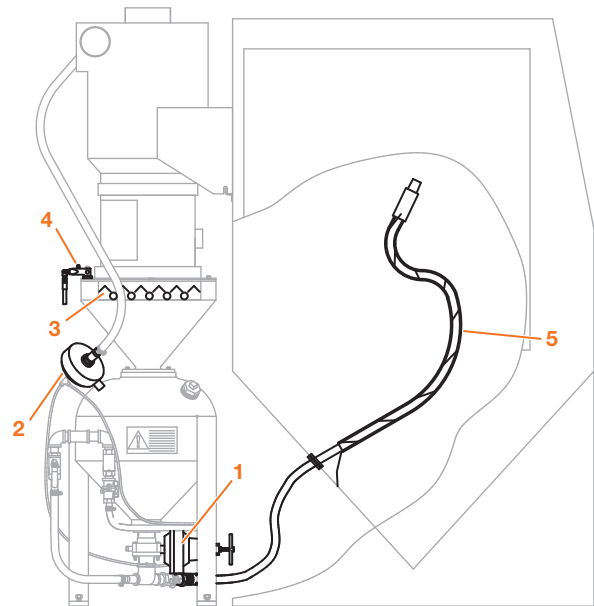

Blast Hose Assembly, 3/4 Inch Urethane for FaStrip®

Item	Description	PART NUMBER
	3/4" ID blast hose assembly (includes items 1 through 14)	140648
1 *	Silicon carbide nozzle, 3/8"	502742
2 *	Nozzle washers, NW-1, 1" ID x 1 5/8" x 1/4" (pack of 10)	524062
3	Nozzle coupling, 1 1/8" ID for 3/4" hose	754571
4	Grounding wire (specify length)	529813
5	Urethane blast hose, 3/4" (specify length)	523221
6 †	Screws for aluminum & brass couplings, #8 x 5/8" (pack of 4) Δ	554232
7	Outer sheath (after 7/92) (6' required) (specify length)	580171
8	Grommet, blast hose, 1" ID x 1 3/8" OD	523931
	Grommet, blast hose, 1 1/2" x 1 3/4" (10/89 to 7/92)	523331
9	Clamp, adjustable, 1 3/4" ID	520581
10	Nipple, 1/2" NPT x 2 1/2"	546052
11	Coupling, TC-1/2, 1/2" MPT	505212
12 *	Washer, AHCW (pack of 10)	524101
	Washer, AHCW (pack of 25)	525102
13	Tag, safety. screw/coupling Δ	564822
14 †	Safety pin (MUST be used on every quick disconnect) Δ	510511

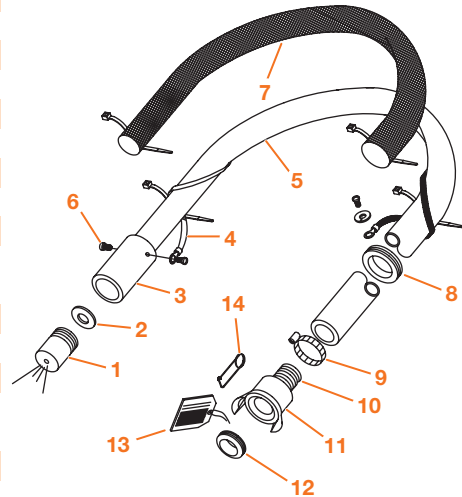

Δ **WARNINGS:** See page A55.

* Recommended spare part—Consumable wear item

† Essential component to prevent downtime

Blast Hose Lengths for FaStrip®

	Bulk	2636	3648	3660	3674	4848	6060
Blast hose length for FaStrip models (includes Ergo-Blast models)		12'	12'	13'	13'	13'	15'
Urethane blast hose, 3/4", maximum length: 50' (specify length)	523221	—	—	—	—	—	—

Blast Nozzles for FaStrip®

SCV-6 is supplied as standard.

Silicon carbide, blue jacket						
Nozzle size	3/16"	1/4"	5/16"	3/8"	7/16"	1/2"
Model	SCV-3	SCV-4	SCV-5	SCV-6	SCV-7	SCV-8
Part Number (each)	502712	502722	502732	502742	502752	502762



Parts: Pro-Finish® FaStrip® Blast Systems

Automatic Sure-Flo® Media Regulator Part Number: 290215

Standard with FaStrip® systems. Optional with other Pro-Finish® systems.

Note: These fasteners are used two places to mount diaphragm body to Sure-Flo® valve.

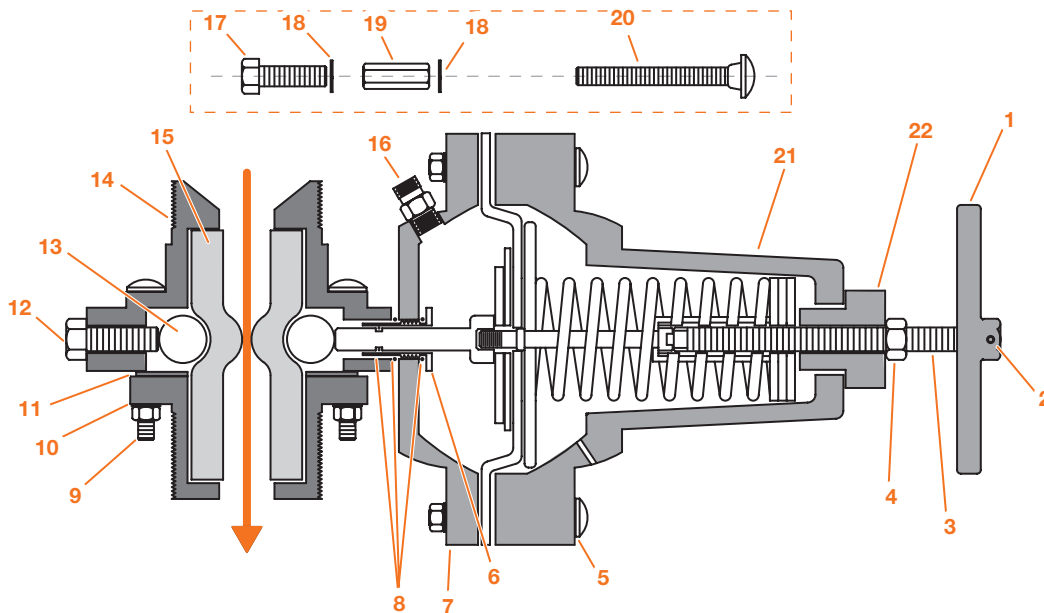

Item	Description	PART #
1	Handle assembly, 1/2" - 13, Auto Sure-Flo (after 5/84)	290217
	Handle only, 1/2" - 13	753622
2	Set screw, 1/4" - 20 x 3/8"	551052
3	Shaft handle	505802
4	Jam nut, 1/2" - 13	552672
5	Carriage bolt, 3/8" - 16 x 2 1/2"	552052
	Lock washer, 3/8" ID	552762
	Hex nut, 3/8" - 16	552542
6	Plunger guide	753462
7	Diaphragm cover	753112
8	O-ring kit (includes 2 for guide, 1 for plunger)	561422
	Carriage bolt, 3/8" - 16 x 2 1/2"	552052
	Lock washer, 3/8" ID	552762
	Hex nut, 3/8" - 16	552542
9	Flange, 2" MPT	753292
10	Roller stop holder	753092
	Screw, 8 - 32 x 1/2" (2 per assembly)	551352
11 †	Bolt, 7/16" - 14 x 1 1/4"	552222
12	Pinch roller (2 per assembly)	753632
13 †	Valve body, 2" MPT	753692
14	Meter tube, 3/4" (See page A50 for choices.)	523592
15 *	Adapter, 1/4" NPT x 1/4" tube	521081
16	Bolt, 3/8" - 16 x 1 1/4" (2, Auto Sure-Flo)	551852
17	Lock washer, 3/8" ID	552762
18	Nut extension, 3/8" - 16 (2, Auto Sure-Flo)	552662
19	Carriage bolt, 3/8" - 16 x 2 1/2"	552052
20	Spring enclosure	753682
21	Spring tensioner	505822

Spring & Diaphragm Detail Part Number: 290296 (Part # 290296 includes items 23 through 28.)

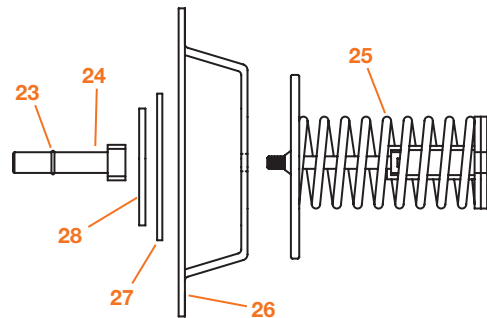

WARNING: Never attempt to disassemble the spring assembly in the automatic Sure-Flo. The spring is under tension and could cause injury to personnel.

Item	Description	PART #
23	O-ring kit (includes 2 for guide, 1 for plunger)	561422
24	Plunger	505872
25	Spring assembly	290296
26	Diaphragm, raised (after 5/84)	525012
	Diaphragm, flat (before 5/84)	523662
27	Diaphragm gasket	525002
28	Washer, 1/2" ID	552842

* Recommended spare part—Consumable wear item
 † Essential component to prevent downtime



Parts: Pro-Finish® FaStrip® Blast Systems

MG-78 CR Exhaust Valve Part Number: 290232

Item	Description	PART #
1	Hose barb, 1"	520181
2	Reducer bushing, 1¼" MPT x 1" FPT	544512
3	Valve body	753332
4	Seat, valve ball (steel)	753412
5	Gasket, seat	524132
6	Valve ball	525322
7	Space washer, steel (½" ID x 2" OD x ¼" thick)	553412
8	Spacer ring, outer	753402
9	Bolt, ⅜" - 16 x 2"	553892
10	Lock washer, ⅜"	552762
11	Washer (½" ID x 2" OD x ⅛" thick)	552842
12	Spacer ring, inner	753392
13	Compression spring	516313
14	Tee, ¼"	545502
15	Elbow, brass, ¼" MPT x ¼" tube (2 required)	520242
16	Nipple, ¼" close	545912
17	Pipe bushing, ½" x ¼"	544462
18	Pipe bushing, ¾" x ½"	544472
19	Bolt, ½" - 13 x 1¾"	551962
20	Valve cover	751801
21	Diaphragm (2 per assembly)	523672
22	Pipe nipple, 1" CLOSE	546192
23	Screws, seat, ¼" - 20 x ½" (pack of 3)	551122
RESTRICTOR PARTS		
23	Nozzle washer, NW-4 (pack of 10)	524082
24	Nozzle washer, NW-1 (pack of 10)	524062
25	Steel washer	552952
26	Ceramic restrictor kit (standard)	290218
	Ceramic nozzle (standard)	502431
	Boron carbide restrictor (replacement)	502081
	Boron carbide restrictor kit (factory upgrade)	290184

Complete rebuild kit (Part # 290183)
(Not shown)

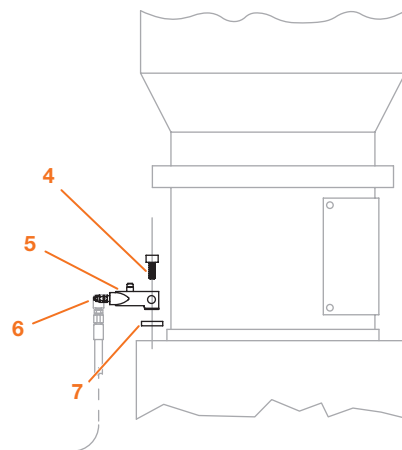
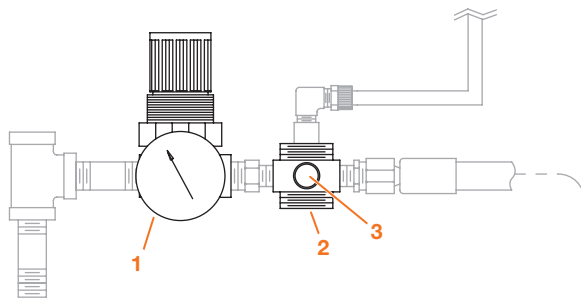
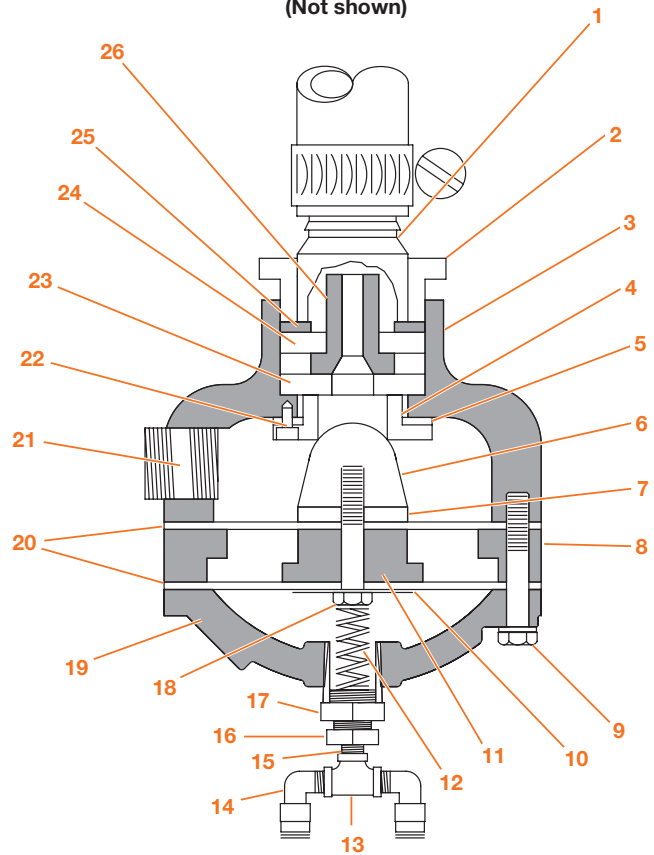

Vibrating Screen Part Number: 140335

Item	Description	PART #
1	Regulator, relieving	517612
2	Air valve, pilot operated	519011
3	Breather vent	523261
4	Socket-head cap	553601
5	Vibrator	517971
6	Muffler, ⅛" bronze	517281
7	Spacer	536359



Parts: Pro-Finish® SafeStrip® Blast Systems

SafeStrip™ blast systems share most of the pressure blast components shown on pages A48 through A50 with other Pro-Finish® pressure models. Differences are highlighted below and on page A55.

SafeStrip™ System

Item	Description	PART #
1	Dust hose, 8" x 15'	516214
2	Adapter, 10" steel to 8" hose	769914
3	Fine-media reclaimer/defuser assembly	140915
4	Reclaimer/defuser top	760126
5	Conveying hose, 6" x 15'	516213
6	Dust hose, 4"	522923
7	Lid	760123
8	Standard cabinet assembly (See page A38.)	—
9	Foot treadle assembly	140579
10	Hose adapter	760431
11	Blast hose, SafeStrip™ (See page A49.)	521672
11	Blast hose, Single-pass (See page A49.)	521672
12	SafeStrip™ pressure vessel (See below.)	260001
12	Single-pass pressure vessel (See page A54.)	140297

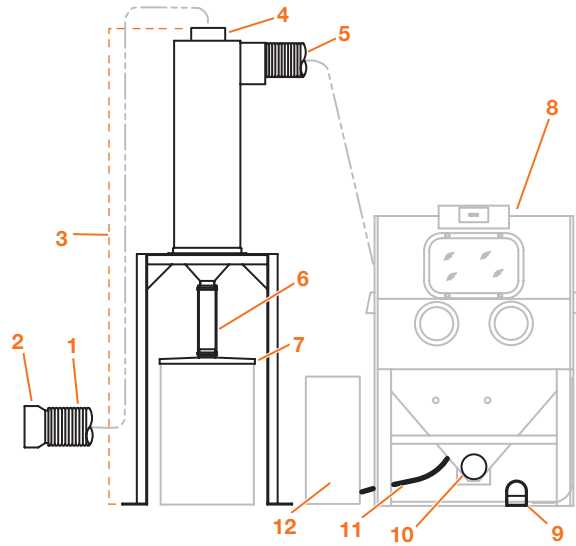

SafeStrip™ Pressure Vessel (Part Number 260001)

Item	Description	PART #
1	Regulator, 2" fixed orifice	340038
	2" metering disc, 1/8" orifice (factory installed)	754633
	2" metering disc, 5/32" orifice (included)	754643
	2" metering disc, 3/16" orifice (included)	754653
2	Manual air valve, 1" NPT	518492
3	Valve, automatic, 1" N.O., S.A.C. bleed	518052
	Diaphragm/seal kit	517582
	Internal parts kit, bleed	518352
4	Gate valve, 1" bronze non-rising stem	515430
5	Regulator, 1" non relieving	517251
6	Inspection door, 6" x 8"	506152
	Nut, inspection door	552303
	Gasket, inspection door	524152
	Bolt, inspection door	506153
7	Differential-pressure gauge	571185
8	Blast-pressure gauge, liquid filled	550391
9	Loading screen	509995
10	Hopper with screen	504325
11	Hopper cover	504326
12	Pin, self locking (2 required per assembly)	510506
13	Sealing plunger (PVC coated), 6"	525072
14	"O" ring, 6" rubber	523872
15	Manual air valve, 1/2" NPT	518472
16	Muffler, 1/2"	506445
17	Check valve, 1" NPT	517503
18	General purpose filter, 1"	517271
	Filter element	580002
19	Automatic Sure-Flo® valve assembly	290215
20	Wheel, 10"	505052
21	Tank coupling, (TCB) 1 1/4" NPT, brass	753262
22	Nipple, heavy duty, 1 1/4" x close	546292
23	Nipple, 2" x close	546452
24	Tee, 1 1/4" x 2"	545752

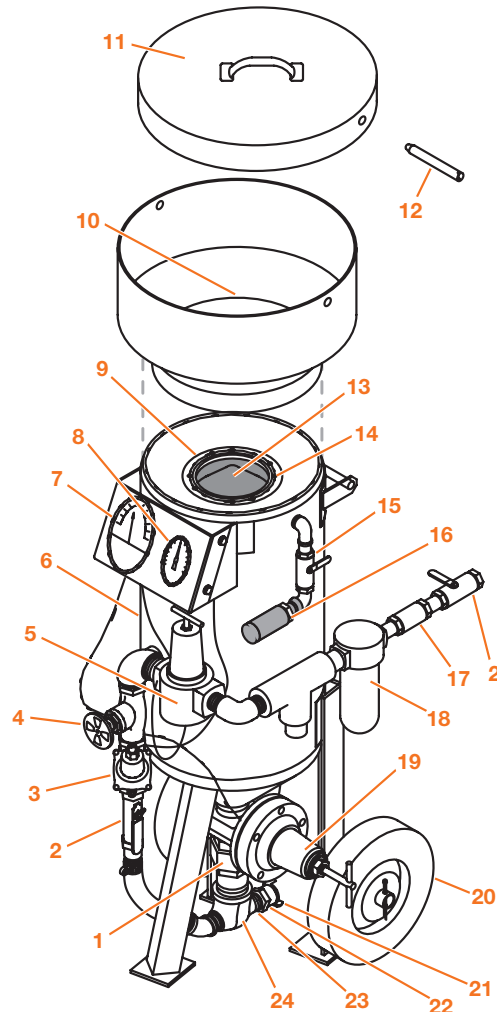

Items Not Shown

•	Control hose assembly, 1/4" x 9" long	520022-9IN
•	Control hose assembly, 1/4" x 14" long	520022-14IN
•	Control hose assembly, 1/4" x 21" long	140853
•	Control hose assembly, 1/4" x 24" long (SB-100)	520022-24IN
•	Control hose assembly, 1/4" x 31" long (SB-150)	520022-31IN
•	Wrench assembly (used with SB-150 only)	140807



Parts: Pro-Finish® Single-Pass Blast Systems

Single-pass models use some equipment that differs from that used with standard Pro-Finish® systems. These items are shown on the previous page in the “SafeStrip™ System” drawing and on this page in the “Single-Pass Pressure Vessel” drawing.

Single-Pass Pressure Vessel

(Part Number 140297 includes items 3 through 13)

Item	Description	PART #
1	Hopper with lid	767363
	Screen (not shown)	767572
2	Gasket	524371
3	Sure-Flo® media regulator, manual (See page A50.)	290383
4	Nipple, 1" NPT x close, HD	546192
5	Tee, 1" x 1" x 1/2" NPT	545822
6	Leveling bolt, 3/8" - 16 x 2", 1 ft ³ (3 per assembly)	551742
	Leveling bolt, 1/2" - 13 x 2 3/4", 3.5 ft ³ (3 per assembly)	551982
7	Hose, 1" ID (Specify 1.5' for 1 ft ³ vessel)	520912
	Hose, 1" ID (Specify 3.5' for 1 ft ³ vessel)	520912
8 †	Hose clamp for 1" ID hose (1 each end)	520581
9	Ball valve, 1" NPT	518492
10	Tee, 1" x 1" x 1/2" NPT	545702
11	Pressure vessel only, 1 ft ³	760811
12	MG-78 exhaust valve (See page A50.)	290182

† Essential component to prevent downtime

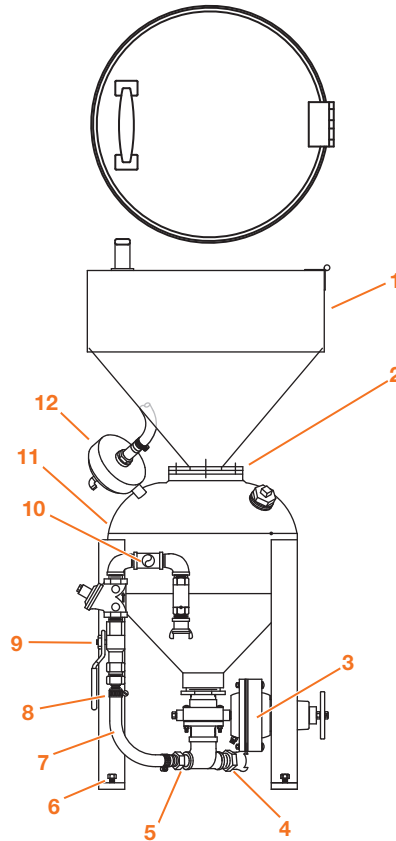

⚠ WARNINGS—Pressure Blast Systems

ALL SYSTEMS

- EMPIRE will not warrant equipment or assume responsibility for damage or injury resulting from neglect or use of improper parts. Failure to follow procedures, which could cause injury and death, constitutes misuse of the product.
- Do not exceed 125 psi inlet pressure.
- Do not disassemble when pressurized or with air supply connected. Be sure all fastenings, including sight plugs, are tightened properly.

PRESSURE VESSEL

- Flange above pop-up valve must be secured before vessel is pressurized.
- Never drill, weld or otherwise alter the pressure vessel. If modifications are required, contact EMPIRE or an A.S.M.E. certified welding shop.

COUPLINGS

- Inspect couplings and blast hose daily for splits, bubbles, soft spots, wear, etc. Make sure nozzle washers are in good condition and screw heads are snug against coupling surfaces. The safety pin (PN 510511) must be in place to prevent disconnection of quick couplings.
- When assembling couplings to blast hose use only #8 x 5/8" long, self-tapping, sheet-metal screws (PN 554232) for cast brass and aluminum couplings and #8 x 3/8" long, self-tapping, sheet-metal screws (PN 554242) for all steel couplings. Use of other types of screws may create a safety hazard.

AUTOMATIC SURE-FLO® MEDIA REGULATOR

- Never attempt to disassemble the spring assembly in the automatic Sure-Flo® media regulator. The spring is under high compression and may injure personnel.

Never use silica sand in any Empire equipment.



Parts: Pro-Finish® Suction Blast Systems

Guide to Part Numbers

Hopper Assembly

Item	Description	PART NUMBER
1	Grommet, air hose, 3/4" x 1 1/16"	523921
2	Grommet, blast hose, 1" x 1 3/8"	523931
3	Gasket, cabinet outlet	524381
4	Outlet adapter, cabinet, 1 1/4" NPT for SAR-2 (no reclaimer)	760441
5	SAR-2 media regulator, complete, 1 1/4" FPT	290156
5a	SAR-2 media regulator, body	753351
5b	Thumb screw, 1/4" - 20 x 1"	551042
5c	Plug, clean out	510121
6	Hopper, 1 gun suction	760751
7 †	Gasket, reclaimer to hopper	524371
8	Pipe nipple, 1 1/4" x 5"	546742
9	Hose clamp, 1/2" air hose (2 per hose)	520502

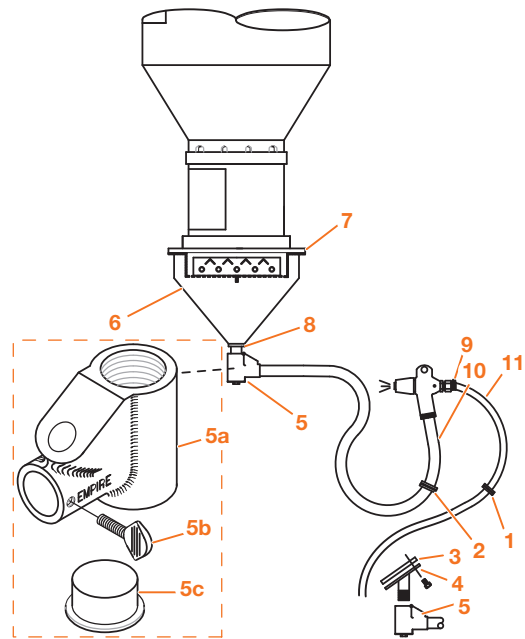

Blast & Air Hoses

Item	Description	Bulk	PART NUMBERS					6060 60120
			2636	3648 3696	3674	3660	4848	
10 *	Blast hose section, 5/8" ID (Blast hose length)	—	522571 (7')	522581 (8')	522591 (9')	522591 (9')	522591 (9')	522601 (13')
	Blast hose section, 5/8" ID, Ergo-Blast (Blast hose length for Ergo-Blast models)	—	522591 (9')	522601 (12')	522601 (12')	522601 (12')	522601 (12')	522601 (13')
	Blast hose, 5/8" ID, maximum length: 50'	520802	—	—	—	—	—	—
11 †	Air-hose assembly, 1/2" ID (Air-hose length)	—	520861 (7.5')	520861 (7')	520861 (8')	520861 (8')	520861 (8')	520861 (10')
	Air-hose assembly, 1/2" ID, Ergo-Blast (Air-hose length for Ergo-Blast models)	—	520861 (10')	520861 (10')	520861 (10')	520861 (10')	520861 (10')	520861 (10')
	Air hose, 1/2" ID, maximum length: 50'	520861	—	—	—	—	—	—

* Recommended spare part—Consumable wear item

† Essential component to prevent downtime



Parts: Pro-Finish® Suction Blast Systems

MH-2 Guns

Item	Description	PART NUMBER
1 *	Gun body, MH-2 long handle	753551
2 *	Ceramic nozzle, 5/16" (standard)	502431
3 *	Air jet, 5/32" (green)	505671
4 *	Nozzle adapter, plastic	505641
5	Spring, suction-gun assist	511251
6	Nut, hose clamp, MH-2	520081
7	O-ring 1 1/16" ID x 1 5/16" OD	523881
8	Screw set, 1/4" - 20 x 3/8"	551052
9	Connector, MH-2	505631
10	Hose barb, 1/2" FPT x 1/2" hose	520402
11	O-ring, 1/2" ID x 5/8" OD (2 required)	523912

* Recommended spare part—Consumable wear item

† Essential component to prevent downtime

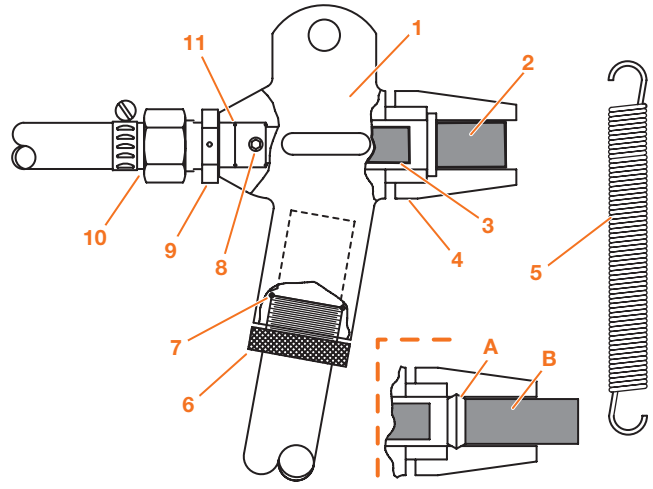

Optional for Wide-Spray Setup

Item	Description	PART NUMBER
A *	Compression ring	752453
B *	Di-Carb™ nozzle, 3/8" wide spray	503573
	Boron nozzle, 3/8" wide spray	503563

* Recommended spare part—Consumable wear item

MH-2 Suction Gun Assemblies

Nozzle (Air Jet) Diameters	PART NUMBERS			PART NUMBERS		
	Long-Handle Gun with			Short-Handle Gun with		
	1/4" (1/8")	5/16" (5/32")	7/16" (7/32")	1/4" (1/8")	5/16" (5/32")	7/16" (7/32")
Ceramic nozzle	505521	505481	505491	505531	505541	505551
Di-Carb™ nozzle	505501	505441	505451	505561	505571	505581
Boron nozzle	505511	505461	505471	505591	505601	505611

• Long-handle gun with 5/16" ceramic nozzle (505481) supplied as standard.

Nozzles for MH-2 Guns

Diameter (#)	1/4" (#4)	5/16" (#5)	7/16" (#7)
	PART NUMBERS		
Ceramic (each)	502421	502431	502441
Ceramic (10 pack)	503341	503351	503361
Di-Carb™ (each)	501331	501341	501351
Boron (each)	502071	502081	502091

Air Jets for MH-2 Guns

Diameter	Designation	Note	PART NUMBER
3/32"	orange		505651
1/8"	yellow		505661
5/32"	green	Standard	505671
3/16"	blue		505681
7/32"	white		505691
1/4"	red		505701





Options Details: Pro-Finish® Cabinets

Cabinet Options (For Pressure or Suction Systems)

PART NUMBERS
FACTORY INSTALLED **CUSTOMER INSTALLED**

Antistatic strap prevents static shock to the operator.	510411	510411
Armrest assembly reduces fatigue. (included with Ergo-Blast models)		
2636 cabinets only	140595	140595
Other cabinets	140596	140596
Door locking clamps prevent unauthorized release of particulates when swing doors are opened.		
Right-door clamp with timer	140628	140630
Right-door clamp without timer	140624	140626
Clamps for two doors with timer	140629	140631
Clamps for two doors without timer	140625	140627
Door mounted basket assembly automates batch processing of small parts.		
Assembly with uncoated basket	140342	140406
Assembly with PVC-coated basket	140404	140405

Door Basket Components

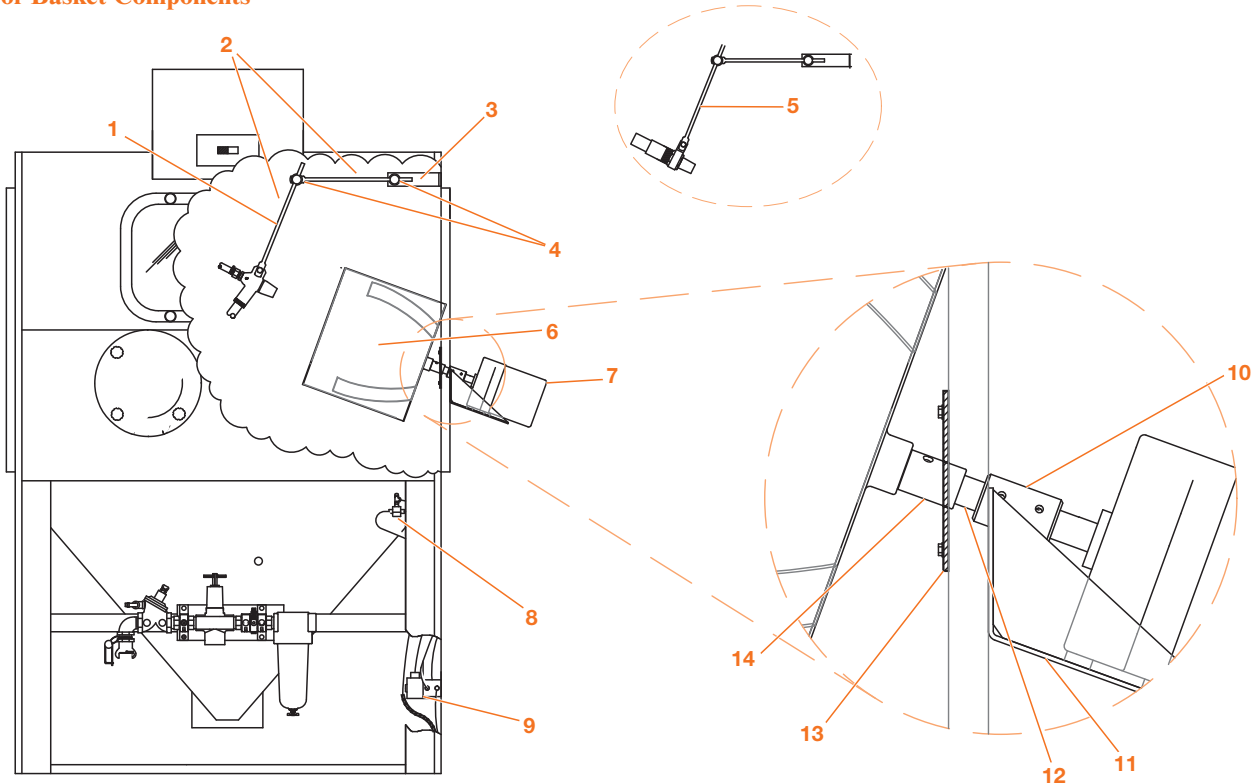

Item	Description	PART #	Item	Description	PART #
1	Gun holder assembly, suction (Includes 2, 3, 4)	140400	8	Shuttle valve, 1/8" NPT	518011
2	Extension arm	510731	9	Solenoid valve	518591
3	Mounting bracket	509541	10	Shaft coupling	570211
4	Knuckle assembly	560231	11	Gear motor bracket	510311
5	Nozzle holder assembly, pressure	140401	12	Shaft	510741
	Nozzle holder pressure, end arm only	509211	13	Shaft seal	523771
6	Basket, 12" x 14", uncoated	510381	14	Basket socket	753751
	Basket, 12" x 14", PVC coated	510911		Electric timer, 0 to 60 minutes (not shown)	531041
7	Motor, 1/4 HP, 115 V/60 Hz/1 ph (6 RPM)	549621			

Glove hole plugs seal cabinet for automated operation.	140623	140622
HEPA inlet filter captures very fine particles. (Cannot be used with sound damper/PN 140597.)	140190	140190
Filter replacement	516303	516303
Magnetic separator extracts ferrous debris during the media-reclamation process.	511572	511572

Options Details: Pro-Finish® Cabinets

Cabinet Options (continued)

PART NUMBERS
FACTORY CUSTOMER
INSTALLED INSTALLED

Oscillator assemblies automate nozzle/gun movement. 140424 140402

Oscillator Components

Item	Description	PART#	Item	Description	PART#
1	Cam roller	509261	8	Thrust bearing	571573
2	Air valve, 1/8" NPT	518581	9	Flange bearing	570141
3	Flow control valve, 1/4" NPT	517743	10	Extension arm	510731
4	Air cylinder	509221	11	Knuckle assembly	560231
5	Air valve, 1/8" NPT	517221		Suction fixed gun holder assembly (includes 10 & 11)	140400
6	Cam operator	509251		Pressure nozzle holder assembly (not shown)	140401
7	Bronze washer	761891	12	Shaft	761871

Rubber curtains shield cabinet interior from harsh abrasives, prolong equipment life. (Part numbers shown below)

FACTORY INSTALLED						
Black Curtains				White Curtains		
Cabinet Size	Cone	Front Wall	Side & Back Walls	Cone	Front Wall	Side & Back Walls
2636	510751	140642	510791	140550	140767	140554
2636 ERGO	510751-ERGO	140642-ERGO	510791-ERGO	140550-ERGO	140767-ERGO	140554-ERGO
3648	510761	140640	510801	140551	140577	140555
3648 ERGO	510761-ERGO	140640-ERGO	510801-ERGO	140551-ERGO	140577-ERGO	140555-ERGO
3660	510782	140827	140828	140829	140830	140831
3660 ERGO	510782-ERGO	140827-ERGO	140828-ERGO	140829-ERGO	140830-ERGO	140831-ERGO
3674	140693	140694	140692	140886	140967	140888
3696*	510761	140640	510801	140551	140577	140555
4848	510771	140640	510811	140552	140577	140556
4848 ERGO	510771-ERGO	140640-ERGO	510811-ERGO	140552-ERGO	140577-ERGO	140556-ERGO
6060	510781	140638	510921	140553	140977	140557
6060 ERGO	510781-ERGO	140638-ERGO	510921-ERGO	140553-ERGO	140977-ERGO	140557-ERGO
60120*	510781	140638	510921	140553	140977	140557
CUSTOMER INSTALLED						
2636	510831	140643	510871	140558	140969	140562
2636 ERGO	510831-ERGO	140643-ERGO	510871-ERGO	140558-ERGO	140969-ERGO	140562-ERGO
3648	510841	140641	510881	140559	140973	140563
3648 ERGO	510841-ERGO	140641-ERGO	510881-ERGO	140559-ERGO	140973-ERGO	140563-ERGO
3660	140832	140833	140834	140835	140836	140837
3660 ERGO	140832-ERGO	140833-ERGO	140834-ERGO	140835-ERGO	140836-ERGO	140837-ERGO
3674	510853	510854	510855	140885	140968	140887
3696*	510841	140641	510881	140559	140973	140563
4848	510851	140641	510891	140560	140973	140564
4848 ERGO	510851-ERGO	140641-ERGO	510891-ERGO	140560-ERGO	140973-ERGO	140564-ERGO
6060	510861	140639	510901	140561	140976	140565
6060 ERGO	510861-ERGO	140639-ERGO	510901-ERGO	140561-ERGO	140976-ERGO	140565-ERGO
60120*	510861	140639	510901	140561	140976	140565

* Twin cabinets require two items for upgrade of both cabinets.

Customer installations on cone and front wall require 1/4"-20 studs, brass grommets and rubber nuts (PN 523533).



Options Details: Pro-Finish® Cabinets

Cabinet Options (continued)

PART NUMBERS
FACTORY INSTALLED **CUSTOMER INSTALLED**

Safety matting protects turntables, cabinet floors and workers. (Two-foot-wide safety matting, with pockets to catch spilled media, is sold by the linear foot. Lengths required are shown below. Specify total length required when ordering.)

509002 509002

	18" Turntable Covering: 2 feet	24" Turntable Covering: 2 feet	36" Turntable Covering: 4 feet	48" Turntable Covering: 8 feet					
	<i>Lengths required for each cabinet size</i>								
	2636	3648	3660	3674	3696	4848	6060	60120	
Floor inside cabinet	3 feet	6 feet	8 feet	10 feet	12 feet	8 feet	13 feet	25 feet	
Shop floor outside:									
cabinet	11 feet	14 feet	15 feet	16 feet	18 feet	16 feet	19 feet	24 feet	
with rolling turntable on dolly	14 feet	16 feet	18 feet	20 feet	20 feet	24 feet	27 feet	32 feet	

PART NUMBERS
FACTORY INSTALLED **CUSTOMER INSTALLED**

System-security key lock prevents unauthorized use of the cabinet.

140864 140864

Timer, electronic, features ease of operation and precise control of on/off intervals. For part replacement information, call factory.

140536 140535

Timer, mechanical, can be set for intervals of up to 60 minutes. For part replacement information, call factory.

140420 140421

Turntables facilitate the processing of heavy parts and provide opportunities to automate. See page A61 and A62 for component part numbers of turntable assemblies.

(Part numbers shown below)

Turntables

Part Numbers shown in this table are Factory Installed and require some field assembly.

STATIONARY TURNTABLES

ROLLING TURNTABLES

MANUAL ROTATION

	18"	18"	24"	36"	48"	18"	24"	36"	48"
Profile:	Std.	Low	Low	Low	Low	Std.	Std.	Std.	Std.
Capacity:	300#	300#	300#	300#	300#	1000#	1000#	1000#	1000#

CABINET SIZES

2636	140422	140574	140502	NA	NA	140321	NA	NA	NA
3648	140422	141530	141532	NA	NA	NA	140322	NA	NA
3660	140422	141531	141533	NA	NA	NA	140324	NA	NA
3674	140422	Call factory	Call factory	NA	NA	Call factory	Call factory	NA	NA
3696*	140422	140530	140532	NA	NA	NA	140322	NA	NA
4848	140422	141530	141532	140503	NA	NA	140322	140323	NA
6060	140422	141531	141533	141534	140848	NA	140324	140325	140448
60120*	140422	141531	140533	141534	140848	NA	140324	140425	NA

POWERED ROTATION

3648	NA	NA	140504	NA	NA	NA	140364	NA	NA
3660	NA	NA	140504	NA	NA	NA	140375	NA	NA
3674	NA	NA	Call factory	NA	NA	NA	Call factory	NA	NA
3696*	NA	NA	140504	NA	NA	NA	NA	NA	NA
4848	NA	NA	141504	140505	NA	NA	140364	140365	NA
6060	NA	NA	140504	140505	NA	NA	140375	140376	NA
60120*	NA	NA	140504	140505	140848	NA	NA	NA	NA

* Two required for both cabinet stations.

NOTES:

- Powered, stationary turntables are not available on Ergo-Blast models.
- Powered turntables require a maximum of 30 SCFM compressed air.
- Part numbers may be used to retrofit existing systems. Customer installation of low-profile turntables requires cutting, fitting and welding.



Options Details: Pro-Finish® Cabinets

Turntables

Powered Turntables

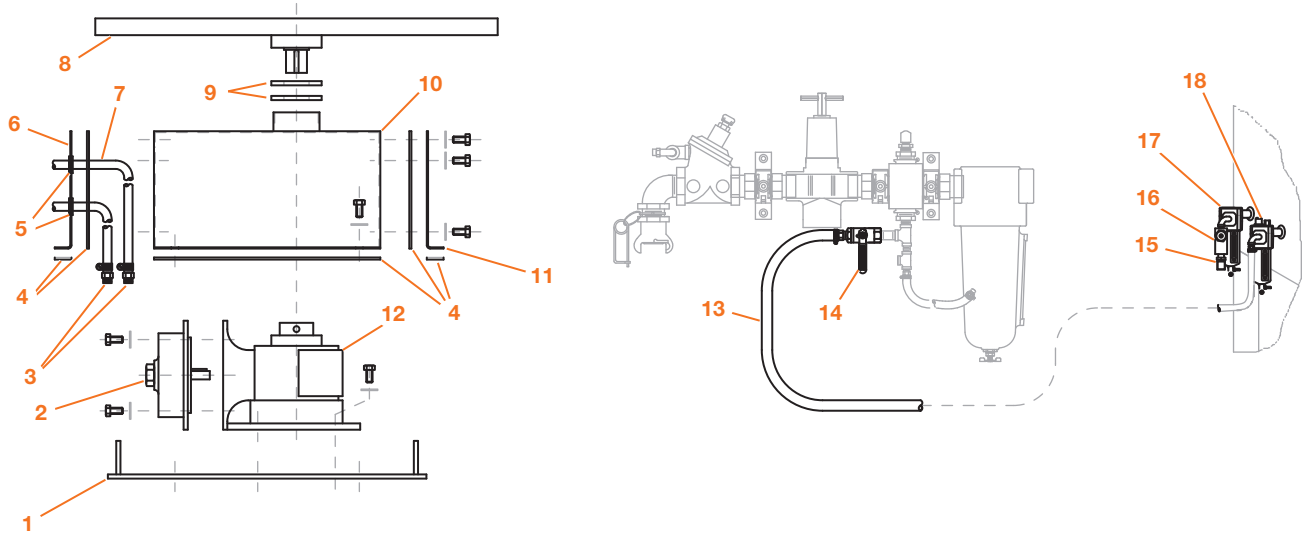

Item	Description	PART #	Item	Description	PART #
1	Mounting plate	768701		Air-hose assembly	
	Air motor	549891		(3648, 1/4" x 6' long)	140861
2	Repair kit, Gast motor	549871	13	(3674, 1/4" x 6' long)	140861
	Repair kit, Fenner-Stone motor	549881		(3660, 1/4" x 6' long)	140861
3	Hose barb, 3/8" NPT to 1/2" hose	520372		(4848, 1/4" x 7' long)	140862
4	Gasket, 1/8" x 1/4" x 5' long	523571		(6060, 1/4" x 8' long)	140863
5	Grommet, 3/4" ID x 1 3/8" (quantity 4)	523921	14	Ball valve, 1/2"	518472
6	End plate, left side	768681	15	Muffler, 1/2" NPT	506443
7	Air hose, 1/2" ID (Specify length.)	520861	16	Flow-control valve, 1/2"	517751
8	24" turntable top	768561	17	Oil-vapor-removal filter, 1/2"	511621
9	Seal (2 required)	516001	18	Lubricator, 1/2"	511631
10	Cover	768641			
11	End plate, right side	768671			
12	Gear reducer	549801			



Options Details: Pro-Finish® Cabinets

Turntables

Table, Cart & Wheels

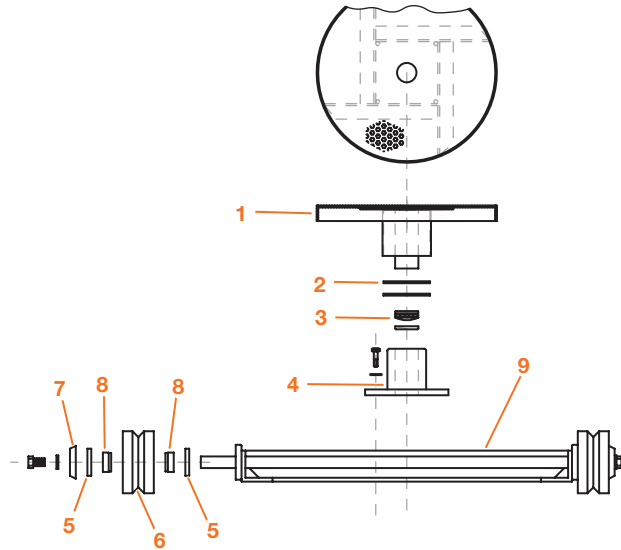

Item	Description	PART #
1	18" turntable	768581
	24" turntable	768591
	36" turntable	768601
	48" turntable	768648
2	Seal (5 required)	516001
3	Bearing thrust	570091
4	Bearing	570141
5	Wheel-bearing seals (2 required per wheel)	
	Inner seal, 2 3/16" OD	525971
	Outer seal, 1 3/4" OD	580351
6	V-groove wheel	509841
7	Outside cup	600291
8	Cotter pin 3/16" x 1 1/4" (before 1987)	553002
8	Hub insert	767071
9	Cart & wheels assembly, 2636 only	140508
	3648, 3660, 4848, 3674 & 6060	140501

Tracks & Platforms

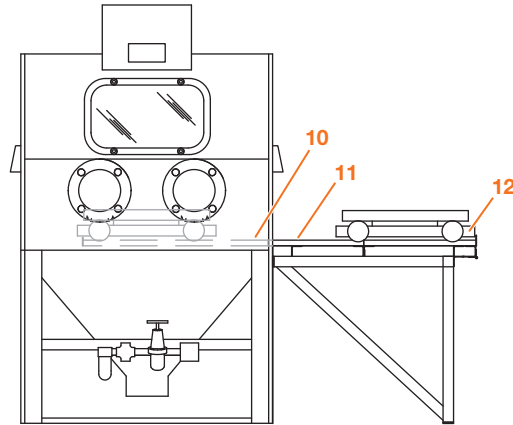

Item	Description	PART #
10	Inside track for: 2636, 1 door	760991
	For: 3648, 3660, 3674, 3696 & 4848, 1 door	761001
	For: 6060 & 60120, 1 door	761021
	For: 3648, 3660, 3674 & 4848, 2 doors	766721
	For: 6060, 2 doors)	766731
11	Outside track for: 2636	760951
	3648, 3660, 3674, 3696. 4848, 6060 & 60120	760961
12	Manual turntable with 18" dolly	140456
	Manual turntable with 24" dolly	140457
	Manual turntable with 36" dolly	140458
	Manual turntable with 48" dolly	140448



Options Details: Pro-Finish® Cabinets

Vertical Doors

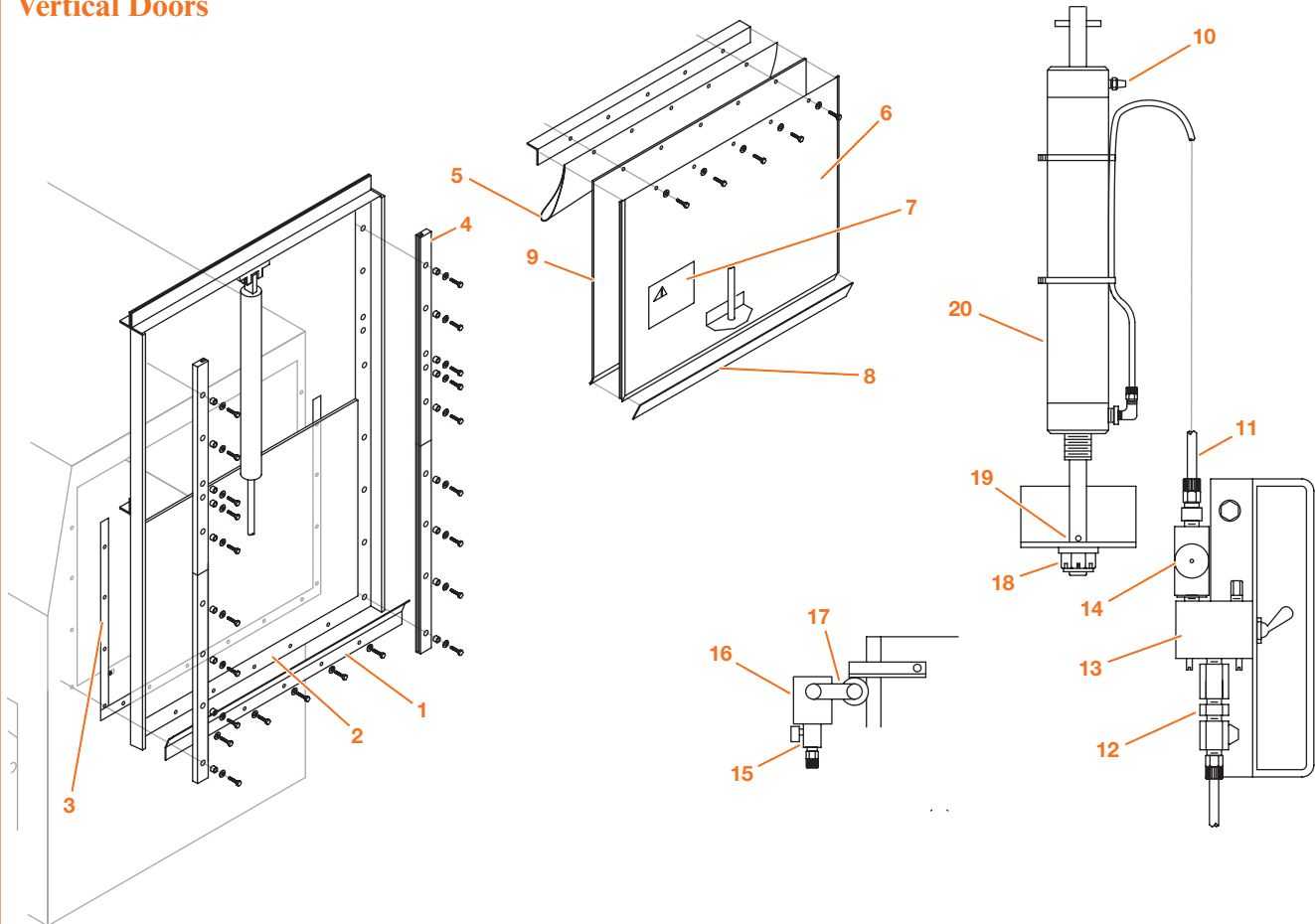

Parts for Vertical Doors		CABINET SIZE					
		2636	3648 3696	3660	3674	4848	6060 60120
Item	Description	PART NUMBERS					
	Vertical door assembly, complete	140491	140490	140490	140490	140489	140488
1	Lower gate	767401	767391	767391	767391	767381	767371
2	Lower gasket	526051	526041	526041	526041	526031	526021
3	Side gasket (4 required for 6060, 2 for others)	526011	526001	526001	526001	525991	525981
4	Track-guide assembly, 2 piece	767344	767340	767340	767340	767340	767340
5	Seal, vertical door	525636	525648	525648	525648	525848	525060
6	Panel, vertical door	767281	767271	767271	767271	767261	767251
7	Caution label	567221	567221	567221	567221	567221	567221
8	Seal, bottom door	526301	526311	526311	526311	526321	526331
9	Gasket, vertical door	526091	526081	526081	526081	526071	526061
10	Muffler	505722	505722	505722	505722	505722	505722
11 *	Polyester tubing (Specify length)	510541	510541	510541	510541	510541	510541
12 *	Check valve, 1/4"	517572	517572	517572	517572	517572	517572
13	Air-control valve, 1/8"	518031	518031	518031	518031	518031	518031
14	Flow-control valve, 1/8"	517721	517721	517721	517721	517721	517721
15	Push button valve	517221	517221	517221	517221	517221	517221
16	Cam operator	509251	509251	509251	509251	509251	509251
17	Cam roller	509261	509261	509261	509261	509261	509261
18	Castle nut	554581	554581	554581	554581	554581	554581
19	Roll pin	554291	554291	554291	554291	554291	554291
20	Air cylinder	518621	518863	518863	518863	518863	518873
	Orifice, .062" (not shown)	752281	752281	752281	752281	752281	752281

* Recommended spare part



Options Details: Pro-Finish® Cabinets

Cabinet Options (continued)

PART NUMBERS	
FACTORY INSTALLED	CUSTOMER INSTALLED

Vibrating screen assures smooth flow of light and fine media. (Included with FaStrip® models.)

140335

140419

Vibrating Screen Components

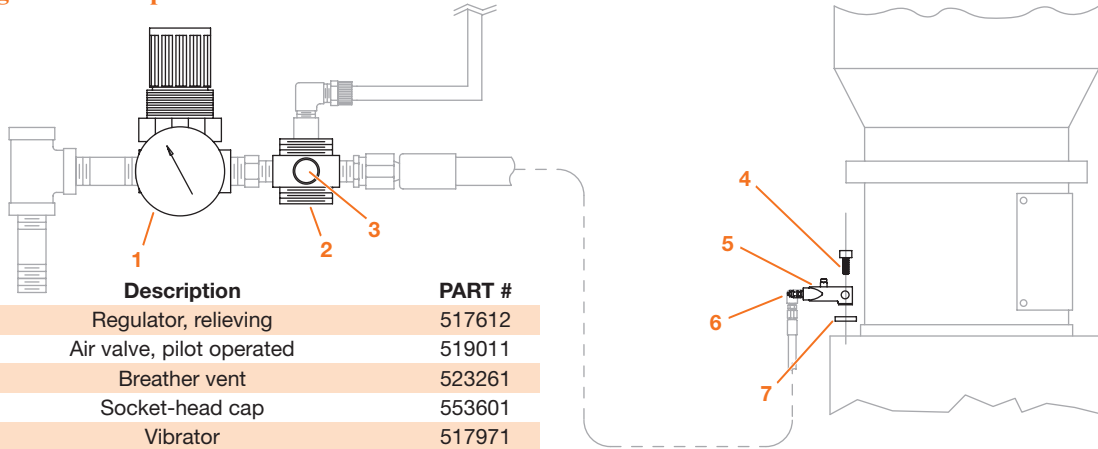

Item	Description	PART #
1	Regulator, relieving	517612
2	Air valve, pilot operated	519011
3	Breather vent	523261
4	Socket-head cap	553601
5	Vibrator	517971
6	Muffler, 1/8" bronze	517281
7	Spacer	536359

Window protector, made of clear plastic, is recommended for use with light, less aggressive abrasives.

509191

509191

Window protector, consisting of a steel screen, protects against heavy and coarse media.

509201

509201



Never use silica sand in any Empire equipment.



Options Details: Pro-Finish® Dust Collectors

Bag House Dust Collector Options

For DCM-80A (PN 112000), DCR-80 (PN 112100), DCM-200 (PN 113000), DCM-200A (PN 113001) & DCM-200B (PN 113002)

PART NUMBERS
FACTORY INSTALLED **CUSTOMER INSTALLED**

Bag shaker, automatic electric, cleans bags thoroughly every time the system is turned off.
 For DCM-80A, DCR-80, DCM-200, DCM-200A & DCM-200B

140340 140390

Bag Shaker, Automatic Electric Components

Item	Description	PART #
1	Pressure switch, differential	550311
2	Timer	531081
3	Flasher	535313
4	Solenoid valve, 120 VAC	517311
5	Cylinder (not included; standard with collector)	515981

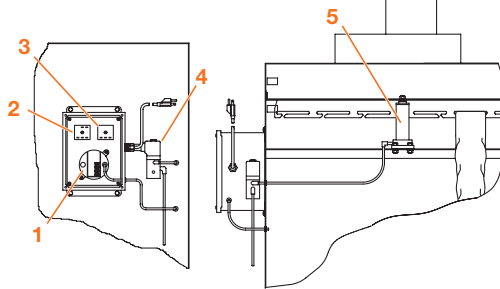

Bag shaker, automatic pneumatic for DCM-80A (Call factory for component part information.)

140685 140686

Bag shaker, automatic pneumatic for DCM-200, DCM-200A & DCM-200B (Call factory for component part information.)

140683 140684

HEPA filter assembly captures very fine particles.

DCM-80A

140215-DCM80A 140215-DCM80A

DCM-200, DCM-200A & DCM-200B

140215 140215

HEPA replacement filter

516305 516305

HEPA filter, pressure differential gauge assembly, monitors filter cleanliness.

140221 140221

Leg extension package for 16 gallon drum includes stand, drum cover and 16 gallon drum

DCM-80A

140259 140258

DCM-200, DCM-200A & DCM-200B

140182 140181

Leg extension package for 55 gallon drum includes stand and drum cover only

DCM-80A

140170/140255 140170/140255

DCM-200, DCM-200A & DCM-200B

140256 140256

Leg extension stand (only) for 16 gallon drum

DCM-80A

140171 140171

DCM-200, DCM-200A & DCM-200B

140185 140185

Leg extension stand (only) for 55 gallon drum

DCM-80A

140170 140170

DCM-200, DCM-200A & DCM-200B

140180 140180

Lid assembly for 16 gallon drum (includes drum)

113015 113015

Components for 16 Gallon Lid Assembly with Drum

Item	Description	PART #
1	Drum, 16 gallon	504016
2	Gasket for lid (5' required)	800166
3	Hose clamp, 4"	520531
4	Adapter (if required)	760412
5	Gum rubber tube, 4" ID x 8" long	523750
6	Lid weldment	850099-1

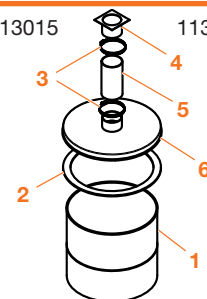

Lid assembly for 55 gallon drum (does not include drum)

140255 140255

Components for 55 Gallon Lid Assembly without Drum

Item	Description	PART #
1	Lid weldment	760123
2	Gasket for lid (7' required)	800166
3	Hose clamp, 4"	520531
4	Adapter (if required)	760412
5	Dust hose, 4" ID x 2' long	522923

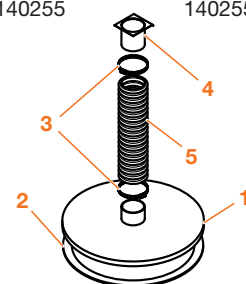

Manometer measures pressure differential

140344 140398

Minihelic Gauge measures pressure differential

140841 140842

Sound attenuator/Damper assembly reduces noise to 85dBA

DCM-80A (400 CFM) & DCM-200 (600 CFM)

140361 140361

DCM-200A (900 CFM)

140769 140769

DCM-200B (1200 CFM)

140680 140680



Options Details: Pro-Finish® Dust Collectors

Cartridge Dust Collector Options

For CDC-6 (PN 113007), CDC-9 (PN 113011) & CDC-12 (PN 113013)

	PART NUMBERS	
	FACTORY INSTALLED	CUSTOMER INSTALLED
HEPA filter assembly captures very fine particles.	140215	140215
HEPA replacement filter	516305	516305
HEPA filter, pressure differential gauge assembly, monitors filter cleanliness.	140221	140221
Leg extension packages for 55 gallon drum include stand and cover (no drum)	140257	140257
Leg extension stand (only) for 55 gallon drum	140185	140185

Lid assembly for 55 gallon drum (does not include drum)	140255	140255
---	--------	--------

Components for 55 Gallon Lid Assembly without Drum

Item	Description	PART #
1	Lid weldment	760123
2	Gasket for lid (7' required)	800166
3	Hose clamp, 4"	520531
4	Adapter (if required)	760412
5	Dust hose, 4" ID x 2' long	522923

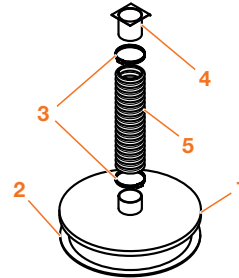

Photohelic automatic pulse cleaning system for cartridge collectors	140900	141900
Photohelic automatic pulse cleaning system for cartridge collectors with leg extensions	141901	141902

Photohelic cartridge cleaning improves system performance, saves operator time.

140900 140900

Photohelic Cleaning Components

Item	Description	PART #
1	Photohelic gauge	550074
2	Solenoid valve	516338
3	Timer board	585090
4	Diaphragm valve (2 required) (Not included; standard on collector)	516352

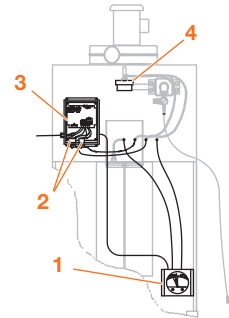

Sound attenuator/damper assembly reduces noise to 85 dBA		
CDC-6 assembly	140361	140361
CDC-9 assembly	140769	140769
CDC-12 assembly	140680	140680

SEM-2 Dust Collector Options

HEPA filter assembly captures very fine particles.	141090	141090
HEPA filter, pressure differential gauge assembly (magnehelic), monitors filter cleanliness.	Call factory	Call factory

Photohelic cartridge cleaning improves system performance, saves operator time.	141810	141811
---	--------	--------

Photohelic Cleaning Components

Item	Description	PART #
1	Photohelic gauge	550074
2	Diaphragm valve (2 required) (Not included; standard on collector)	516343
3	Solenoid valve	516335
4	Timer board	585090

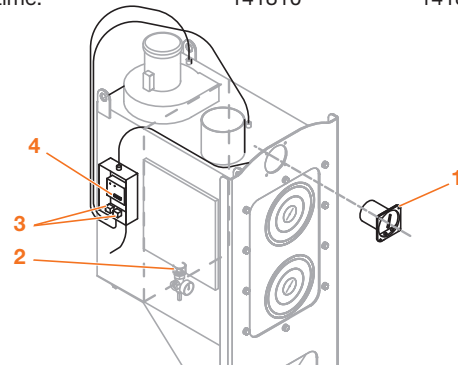

Sound attenuator assembly		
SEM-2 (400 & 600 CFM) 85 dBA	140966	140966
SEM-2 (400 & 600 CFM) premium 80 dBA	141794	141795



Options Details: Pro-Finish® Dust & Conveying Hose

Dust and Conveying Hose Options

RECLAIMER CAPACITY	Description	400 CFM	600 CFM	900 CFM	1200 CFM
		PART NUMBERS			
	Dust hose for optional 3.5 ft ³ pressure vessel (I.D. x length)	515631 (6" x 25')	515631 (6" x 25')	516999 (10" x 15')	516999 (10" x 15')
	Conveying hose, heavy duty, with clamps, factory upgrade ** (I.D. x length)	140338 (4" x 9')	140338 (4" x 9')	140339 (6" x 12')	140339 (6" x 12')
	Conveying hose, heavy duty, with clamps, customer install (I.D. x length)	140354 (4" x 9')	140354 (4" x 9')	140355 (6" x 12')	140355 (6" x 12')
	Conveying hose, 4" I.D., heavy duty to length (Specify length)	515911	515911	515911	515911
	Conveying hose, 6" I.D., heavy duty to length (Specify length)	515921	515921	515921	515921
	Conveying hose, standard duty, for optional 3.5 ft ³ pressure vessel (I.D. x length)	516033 (4" x 15')	516033 (4" x 15')	516115 (6" x 15')	516115 (6" x 15')
	Conveying hose, heavy duty, for optional 3.5 ft ³ vessel, factory upgrade **	140613	140613	140614	140614
	Conveying hose, heavy duty, for optional 3.5 ft ³ vessel, customer install (I.D. x length)	140611 (4" x 15')	140611 (4" x 15')	140612 (6" x 15')	140612 (6" x 15')
	Hose clamp, heavy duty conveying hose	522953	522953	522963	522963

** Not to be ordered as replacement hose



Options Details: Pro-Finish® Reclaimers

Reclaimer Options

	PART NUMBERS	
	FACTORY INSTALLED	CUSTOMER INSTALLED
Ultrawear lining extends reclaimer life by a factor of ten. (Not available with 400 CFM reclaimers.)		
600 CFM reclaimers	526183	NA
900-1200 CFM reclaimers	526193	NA

Inlet wear plate extends reclaimer life by shielding the reclaimer's most vulnerable area.

400 CFM reclaimers	514471	514501
600 CFM reclaimers	514481	514511
900-1200 CFM reclaimers	514491	514521

Reclaimer Wear Plate Components

CAPACITY (SCFM)	400	600	900/1200
A Rubber band	524871	524881	524891
B Bolt, 3/8" - 16 x 2" (3 required)	553892	553892	553892
C Metal band	761601	761611	761621
D Bolt, 3/8" - 16 x 1 1/2" (3 required)	551262	551262	551262
E Nut, 3/8" - 16	552542	552542	552542

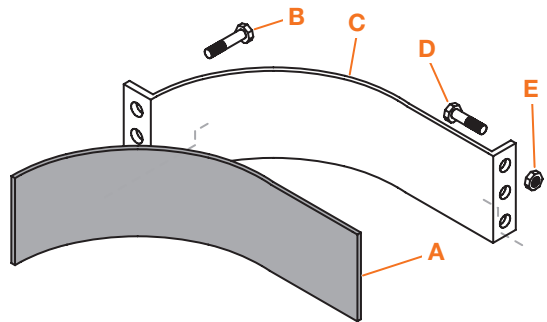

Options Details: Pro-Finish® Pressure Blast Systems

Pressure Blast System Options

	PART NUMBERS	
	FACTORY INSTALLED	CUSTOMER INSTALLED
Blast hose assembly (1/2" top entry) takes weight off the operator's hands. (See page A49 for detail.)	140878	140879

Blast hose assembly (3/4", top entry) with 1/4" Di-Carb™ nozzle adds ease of handling, higher air/media capacity and longer nozzle life.	140635	140634
---	--------	--------

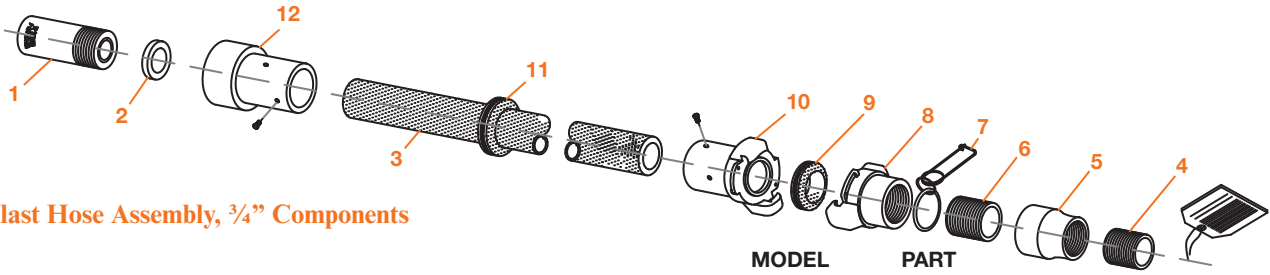

Blast Hose Assembly, 3/4" Components

Item	Description	MODEL NUMBER	PART NUMBER
1	Nozzle, 1/4" Di-Carb™	DC3-4	501402
2	Nozzle washer, (10 pack)	NW-1	524062
3	Blast hose, 3/4" ID (specify length)	PBH-3/4	520812
4	Pipe nipple, 1" x close	-	546192
5	Bell reducer, 1 1/4" x 1"	-	545341
6	Pipe nipple, 1 1/4" x close	-	546292
7 †	Safety pin Δ	-	510511
8	Tank coupling, 1 1/4"	-	753262
9	Quick coupling washer (10 pack)	QCW	524032
	Quick coupling washer (25 pack)	QCW	525092
10	Quick coupling with washer and screw package	QC-3/4	751062
11	Grommet, blast hose, 1 1/2" x 1 5/8"	-	523331
12 †	Nozzle coupling	NC-3/4	753212

Δ **WARNINGS:** See page A55. † Essential component to prevent downtime

Cone with 60° slope assures smooth flow of bridgeable media. Pressure vessel assemblies, 1 ft³ and 3 1/2 ft³ with 60° cone	Call	Call
---	------	------

Constant pressure control assembly maintains desired pressure, improves blasting consistency	140523	141521
Assembly for systems with automatic Sure-Flo®	141520	141522
Assembly for systems without automatic Sure-Flo®		

Constant pressure control components

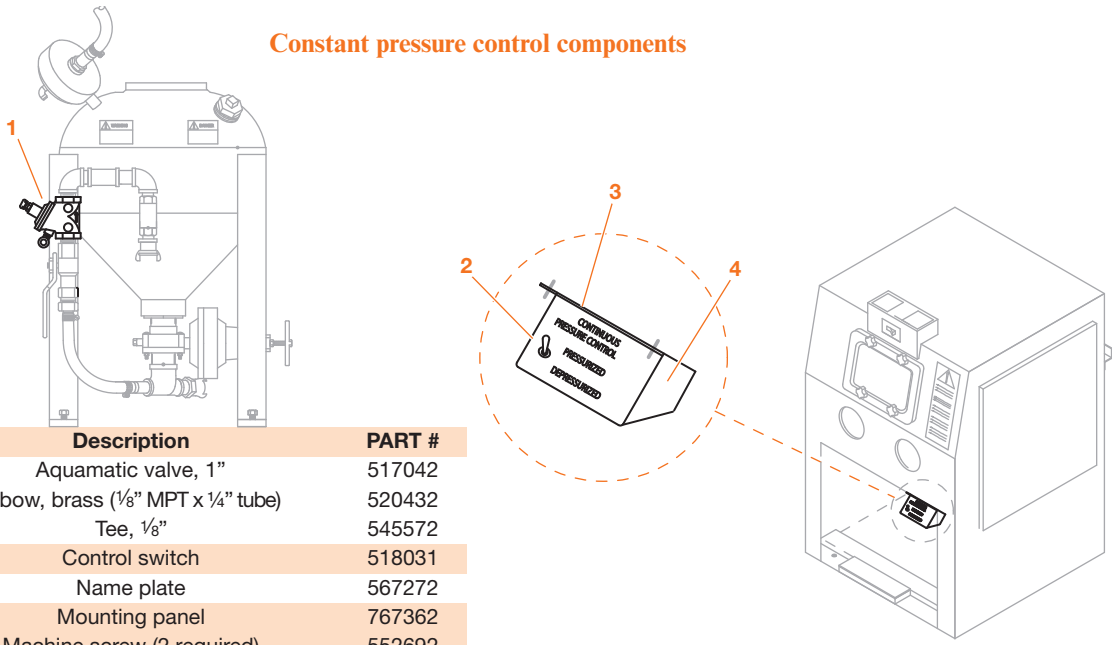

Item	Description	PART #
	Aquamatic valve, 1"	517042
1	Elbow, brass (1/8" MPT x 1/4" tube)	520432
	Tee, 1/8"	545572
2	Control switch	518031
3	Name plate	567272
	Mounting panel	767362
4	Machine screw (2 required)	552692



Options Details: Pro-Finish® Pressure Blast Systems

Pressure Blast System Options (continued)

PART NUMBERS
FACTORY INSTALLED CUSTOMER INSTALLED

Door sill package, standard with Ergo-Blast models, catches dust and debris when a cabinet door is opened after blasting. (One package is required per door.)

(Part numbers shown below)

Door sill Packages

CABINET SIZES AND PART NUMBERS

	2636	3648	3660	3674	3696	4848	6060	60120
Factory Installed Part #	140725	140726	140726	140726	140726	140727	140728	140728
Customer Installed Part #	140725	140726	140726	140726	140726	140727	140728	140728

Fine tuning package with choke enables the operator to clear clogs in the grit valve, as well as adjust the media/air mix, from the work station.

140509 140510

Fine tuning components

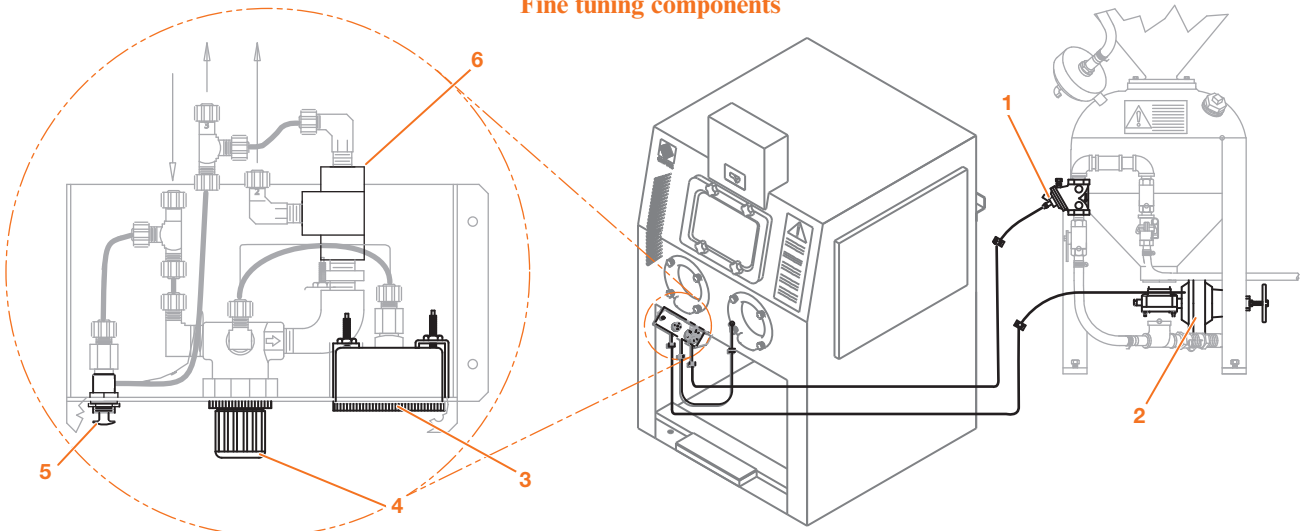

Item	Description	PART #
1	Aquamatic valve, 1"	517692
2	Sure-Flo valve, automatic	290215
3	Pressure gauge	550212
4	Regulator, relieving, 1/4"	517613
5	Air valve, push button	517221
6	Shuttle valve, 1/8"	518011

Never use silica sand in any Empire equipment.



Options Details: Pro-Finish® Pressure Blast Systems

Pressure Blast System Options (continued)

PART NUMBERS
FACTORY INSTALLED **CUSTOMER INSTALLED**

Media low-level sensor & indicator warn when the media supply is low.

140381

Call

Media Low Level Sensor & Indicator Components

Item	Description	PART #
1	Level sensor	600880
2	Indicator lamp (red)	532743

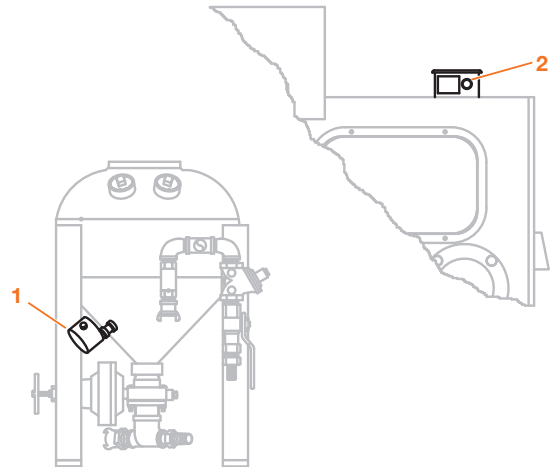

Media regulator with aeration promotes smooth flow of fine and light grit.

140374

140360

Aerated Media Regulator Components

Item	Description	PART #
1	Tee, 1" NPT	545532
2	Hex bushing, 1" x 1/4" NPT	544482
3	Connector, brass, 1/4" MPT x 1/4" tube	521081
4	Nipple, 2 1/2"	546601
5	Upper ring	753581
6	Washer disc seal	524971
7	Washer inner-disc seal	524961
8	Regulator body	753601
9	Clamp knob	511041
10	Hex bushing, 1/4" x 1/8" NPT	544302
11	Clamp	753591
12	Metering orifice, 1/16"	762651
	Metering orifice, 3/32"	762661
	Metering orifice, 1/8"	762671
	Metering orifice, 5/32"	762681
	Metering orifice, 3/16"	762691
	Metering orifice, 7/32"	762701
	Metering orifice, 1/4"	762711
13	Metering orifice, 9/16"	762721
	Metering orifice, 3/8"	762731
14	Aeration disc	511031
	O-ring	524941

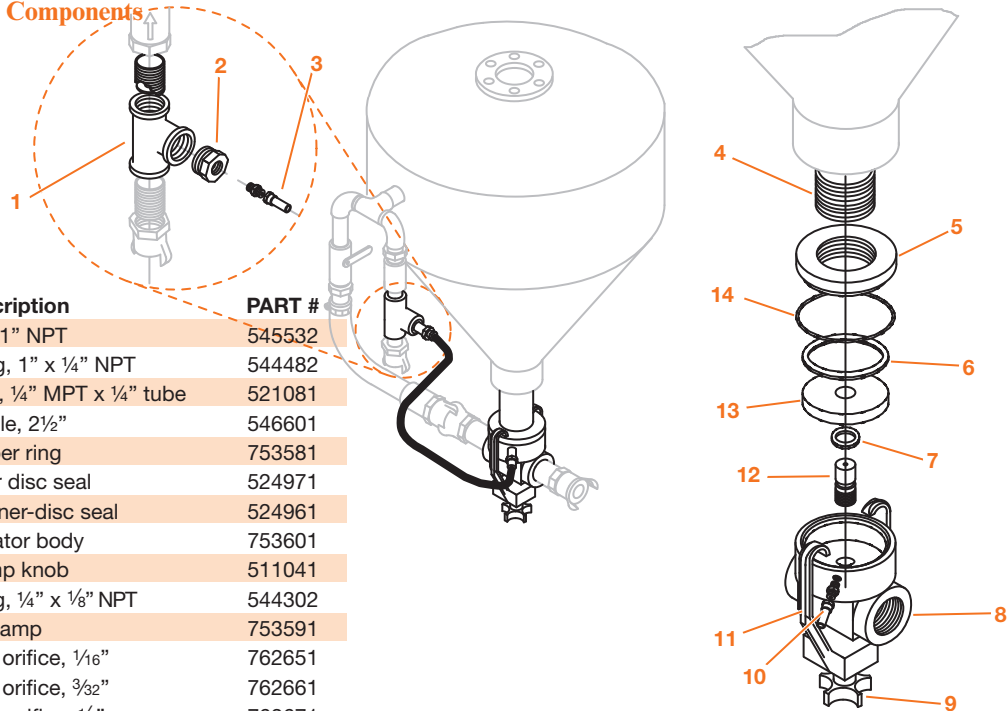



Options Details: Pro-Finish® Pressure Blast Systems

Pressure Blast System Options (continued)

PART NUMBERS
FACTORY INSTALLED **CUSTOMER INSTALLED**

MG-78 CR exhaust valve works in combination with the automatic Sure-Flo® media regulator to improve vessel refill with fine media.

290234 290232

Boron restrictor extends MG-78 CR valve life.

290184 290184

MG-78 CR Exhaust Valve Components

Item	Description	PART #
1	Hose barb, 1"	520181
2	Reducer bushing, 1¼" MPT x 1" FPT	544512
3	Valve body	753332
4	Seat, valve ball (steel)	753412
5	Gasket, seat	524132
6	Valve ball	525322
7	Space washer, steel (½" ID x 2" OD x ¼" thick)	553412
8	Spacer ring, outer	753402
9	Bolt, ⅜" - 16 x 2"	553892
	Lock washer, ⅜"	552762
10	Washer (½" ID x 2" OD x ⅛" thick)	552842
11	Spacer ring, inner	753392
12	Compression spring	516313
13	Tee, ¼"	545502
14	Elbow, brass, ¼" MPT x ¼" tube (2 required)	520242
15	Nipple, ¼" close	545912
16	Pipe bushing, ½" x ¼"	544462
17	Pipe bushing, ¾" x ½"	544472
18	Bolt, ½" - 13 x 1¾"	551962
19	Valve cover	751801
20	Diaphragm (2 per assembly)	523672
21	Pipe nipple, 1" CLOSE	546192
22	Screws, seat, ¼" - 20 x ½" (pack of 3)	551122
RESTRICTOR PARTS		
23	Nozzle washer, NW-4 (pack of 10)	524082
24	Nozzle washer, NW-1 (pack of 10)	524062
25	Steel washer	552952
	Ceramic restrictor kit (standard)	290218
	Ceramic nozzle (standard)	502431
26	Boron carbide restrictor kit (replacement)	502081
	Boron carbide restrictor kit (factory upgrade)	290184

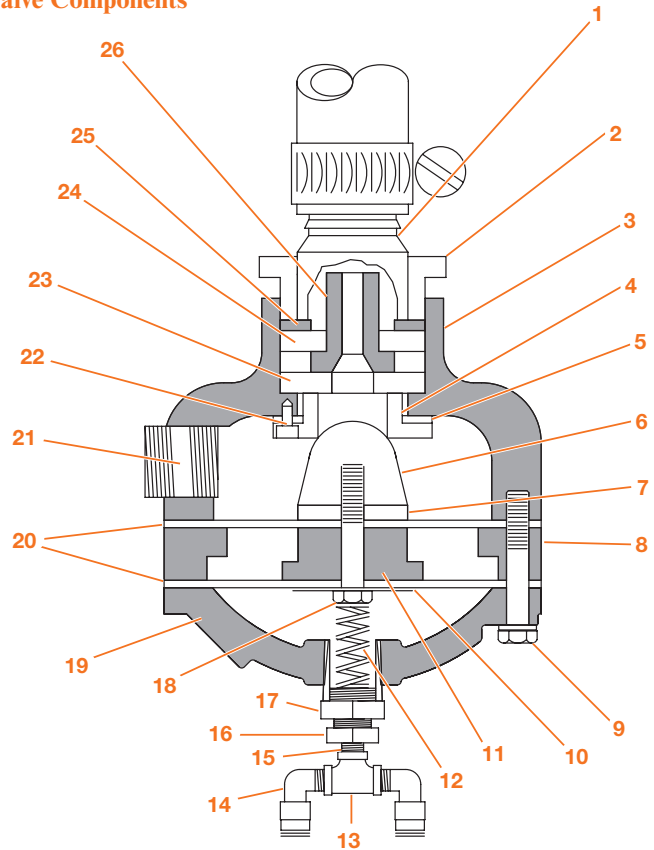

Complete rebuild kit, MG-72/MG-78 valve (Part # 290183), not shown

Nozzle holder frees the operator's hands to manipulate parts.

140401 140401

Never use silica sand in any Empire equipment.



Options Details: Pro-Finish® Pressure Blast Systems

Pressure Blast System Options (continued)

PART NUMBERS	
FACTORY INSTALLED	CUSTOMER INSTALLED

Sure-Flo® automatic media regulator, standard with FaStrip® models, supports Fine Tuning Packages for more precise media control.

290215 290215

Automatic Sure-Flo® Media Regulator Components

Note: These fasteners are used two places to mount diaphragm body to Sure-Flo® valve.

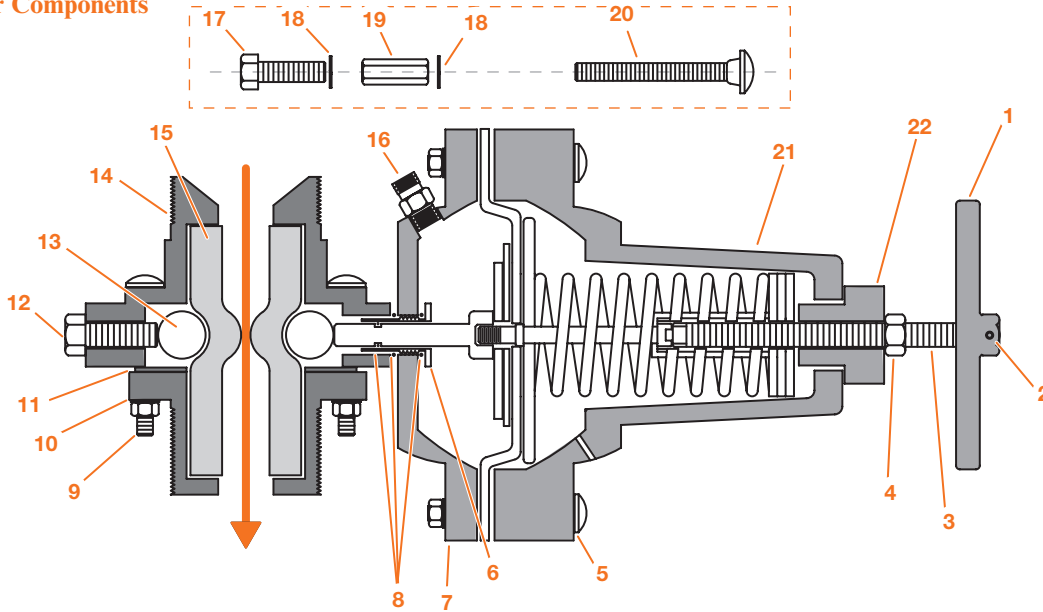

Item	Description	PART #
1	Handle assembly, 1/2" - 13, Auto Sure-Flo (after 5/84) Handle only, 1/2" - 13	290217 753622
2	Set screw, 1/4" - 20 x 3/8"	551052
3	Shaft handle	505802
4	Jam nut, 1/2" - 13	552672
5	Carriage bolt, 3/8" - 16 x 2 1/2" Lock washer, 3/8" ID	552052 552762
6	Hex nut, 3/8" - 16	552542
7	Plunger guide	753462
8	O-ring kit (includes 2 for guide, 1 for plunger)	561422
9	Carriage bolt, 3/8" - 16 x 2 1/2" Lock washer, 3/8" ID Hex nut, 3/8" - 16	552052 552762 552542
10	Flange, 2" MPT	753292
11 †	Roller stop holder	753092
12	Screw, 8 - 32 x 1/2" (2 per assembly)	551352
13	Bolt, 7/16" - 14 x 1 1/4"	552222
14 †	Pinch roller (2 per assembly)	753632
15 *	Valve body, 2" MPT	753692
16	Meter tube, 3/4" (See page A50 for choices.) Adapter, 1/4" NPT x 1/4" tube	523592 521081
17	Bolt, 3/8" - 16 x 1 1/4" (2, Auto Sure-Flo)	551852
18	Lock washer, 3/8" ID	552762
19	Nut extension, 3/8" - 16 (2, Auto Sure-Flo)	552662
20	Carriage bolt, 3/8" - 16 x 2 1/2"	552052
21	Spring enclosure	753682
22	Spring tensioner	505822

Spring & Diaphragm Detail (Part # 290296) (Part # 290296 includes items 23 through 28.)

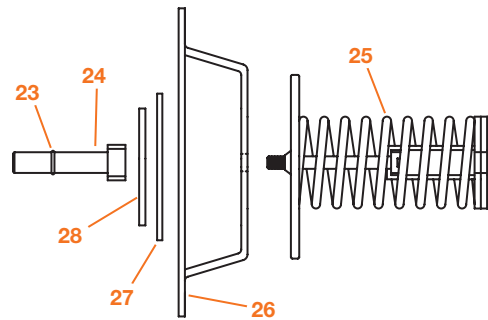

WARNING: Never attempt to disassemble the spring assembly in the automatic Sure-Flo. The spring is under tension and could cause injury to personnel.

Item	Description	PART #
23	O-ring kit (includes 2 for guide, 1 for plunger)	561422
24	Plunger	505872
25	Spring assembly	290296
26	Diaphragm, raised (after 5/84) Diaphragm, flat (before 5/84)	525012 523662
27	Diaphragm gasket	525002
28	Washer, 1/2" ID	552842

* Recommended spare part—Consumable wear item
† Essential component to prevent downtime

Never use silica sand in any Empire equipment.



Options Details: Pro-Finish® Pressure Blast Systems

Pressure Blast System Options (continued)

PART NUMBERS
FACTORY INSTALLED **CUSTOMER INSTALLED**

Vessel, 3.5 cubic-foot pressure assembly, reduces time required for media refills.
 Vessel for 400 and 600 CFM applications
 Vessel for 900 and 1200 CFM applications
 Sight glasses, 2" NPT
 60° cone

140609	140607
140610	140608
545493	545493
Call	Call

Pressure Vessel (3.5 ft³) Components

Item	Description	PART #
1	Tee, 1" x 1" x 2"	545822
2	Aquamatic valve, 1"	517042
3	Ball valve, 1"	518492
4	MG-78 exhaust valve	290182
5	Hose barb	520181
6	Exhaust hose assembly	140691
7	Access window	526231
8	Hopper assembly, 3½ cubic foot	290475
9	Gasket, ¼" x 1" x 3½' long, closed cell	523622
10	Gasket, 1" x 1½" x 12' long	523641
11	O-ring	523872
12	6" Plunger	525072
13	Sure-Flo® media regulator, automatic	290215

See page A46 for hose requirements and hose options.

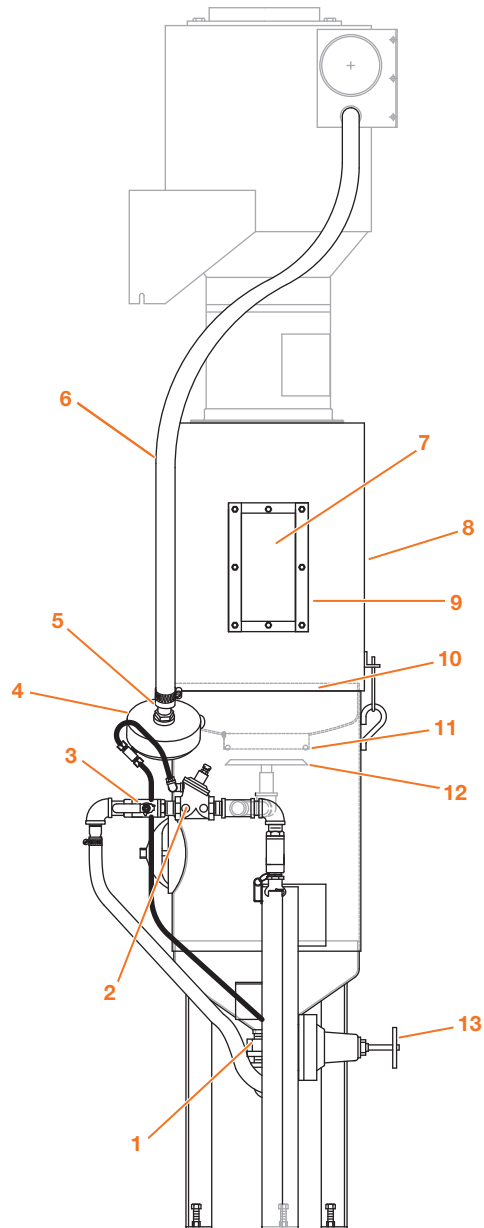



Options Details: Pro-Finish® Suction Blast Systems

Suction Blast System Options

	PART NUMBERS FACTORY INSTALLED	CUSTOMER INSTALLED
Gun holder frees the operator's hands to manipulate parts.	140400	140400
Gun package supporting a second gun expands the work envelope.	140347	140351
Gun package supporting two additional guns for a total of three (3).	140348	140352
Gun package supporting three additional guns for total of four (4).	140349	140353
Media storage hopper with 2 cubic-foot capacity mounts to bottom of reclaimer.	760922	760922
Pipe string upgrade with 1" NPT required to supply additional air for multi-gun packages.	140310	140310

Components for Multiple Gun Packages

Item	Description	PART #
1	Blast hose, 5/8" (Specify length)	520802
2	Thumb screw, 1/4"- 20 x 1"	551042
3	Plug, clean out	510121
4	SAR-2 regulator body	753351
5	SAR-2 assembly (includes 2 through 5)	290156
6	Pipe nipple, 1" NPT x 5"	546741
7	Hopper weldment, 2 ft ³ , multi-gun	760922
8	Gasket, reclaimer to hopper	524371
9	Air hose, 1/2" (Specify length)	520861
10	Ball valve, 1/2" NPT	518472
11	1" Pipe-string assembly included with customer installed (See page A47 for details.)	140280
12	MH-2 gun, short handle, 5/16" jet	505541
13	Grommet, 1" ID x 1 3/4" OD	523931
14	Grommet, 3/4" ID x 1 3/8" OD	523921
15	Arm extension	510731
16	Knuckle assembly	560231
17	Fixed-gun holder assembly (includes 14 & 15)	140400

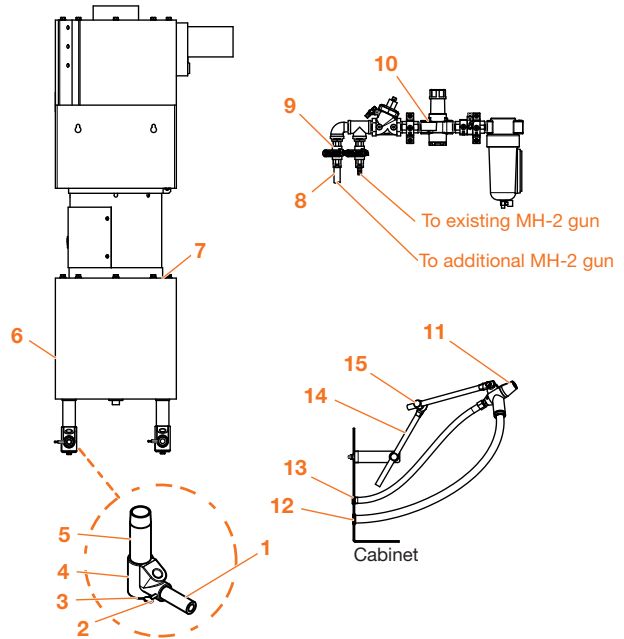

NOTE: Free standing media storage hopper with 4 cubic-foot capacity (old style) still available. Call factory for pricing.

KLEEN™ package prevents dust from dropping onto the floor when cabinet doors are opened and returns pressurized media to the cabinet in the event that a blast nozzle plugs.

2636 cabinets	140356	140391
3648, 3660, 3674 and 3696 cabinets	140357	140392
4848 cabinets	140358	140393
6060 and 60120 cabinets	140359	140394

Suction conversion kit includes parts to switch cabinets from pressure to suction.

Suction Conversion Kit Components

Item	Description	PART #
1	Storage hopper	760751
2	Gasket, reclaimer to hopper	524371
3	Plug	544122
4	MH-2 suction gun with 5/16" ceramic nozzle	505481
5	Air hose	522861
6	Grommet, 3/4" ID x 1 3/8" OD	523921
7	Grommet, 1" ID x 1 3/4" OD	523931
8	Blast hose, 5/8"	520802
9	Media regulator, SAR-2	290156

